



产品规格书

PRODUCT SPECIFICATION

客户名称Buyer Name	
客户料号Buyer Part No.	
客户承认签章 Buyers Approval & Signatures	

文件编号Spec No.		版本	A/1
品名描述 Product Description	圆柱直流马达 Cylindrical DC motor		
型号Part No.	VZ6SH1A0060711		
送样日期Date			
设计Designed by	审核Checked by	批准Approved by	
2020.07.01	2020.07.01	2020.07.01	

www.vybronic.com
sales@vybronic.com

规格书内容/Contents

1、适用范围/ General Scope	3/9
2、使用条件/ Operating Conditions	3/9
3、测定条件/ Measuring Conditions	3/9
4、机械要求/ Mechanical Specifications	3/9
5、性能特征/ Performance and characteristics	4/9
6、可靠性/ Reliability	5/9
7、要求/ Requirements	6/9
8、使用时注意事项/ Attentions	6/9
9、包装/ Packaging	7/9
10、外形图/ Outline Drawing	8/9
11、修改记录/ Revision History	9/9

1. 适用范围/ General Scope

本说明书适用于圆筒式永磁直流电机 VZ6SH1A0060711 型

This specification applies to cylindrical permanent-magnetic motors DC model VZ6SH1A0060711

2. 使用条件/ Operating Conditions

项目/Item		规格/Specifications	条件·备注/Conditions & Remarks
2-1	额定电压 Rated voltage	1.3V DC	
2-2	额定负荷 Rated load	振子 Counterweight	见 10. 外形图 As specified in 10. Outline Drawing
2-3	旋转方向 Rotation	C.W/C.C.W (clockwise or counter clockwise)	
2-4	马达位置 Motor position	全方位 All position	
2-5	使用电压范围 Operating voltage	0.9~1.6V DC	
2-6	使用环境 Operating environment	-30 ~ 70℃, 常湿 /Ordinary Humidity:65±20%RH	无水气凝结 No condensation of moisture
2-7	保存环境 Storage environment	-40 ~ 80℃, 常湿 /Ordinary Humidity:65±20%RH	无水气凝结 No condensation of moisture

3. 测定条件/Measuring condition

项目/Item		规格/Specifications	条件·备注/Conditions & Remarks
3-1	温度 Temperature	20±2℃	
3-2	湿度 Humidity	(63%~67%) RH	
3-3	位置 Motor position	轴向水平 Motor shaft horizontal	将马达固定在试验台上 Lock the motor in a test fixture

标准测试条件为温度 20℃, 湿度 65%。如无疑异, 也可在温度 5~35℃、湿度 45~85% 的条件下测试。马达测试时, 放置方向为轴向水平。/The measurement at 20℃ & 65%RH is standard. If the judgment is not questionable, recognize measurement at 5℃ to 35℃ & relative humidity 45% to 85%. Direction of motor is shaft horizontal.

4. 机械要求/ Mechanical specification

项目/Item		规格/Specifications	条件·备注/Conditions & Remarks
4-1	结构 Configuration	见 10. 外形图 As specified in 10. Outline Drawing	Outline drawing No: VZ6SH1A0060711
4-2	外观 Appearance	不含有机械损坏及不适当的浸蚀等。 There shall be no evidence of mechanical damage and shall not have inadequate corrosion and so on	目测 (容许范围根据样品外形) Visual examination(allowable extent is based on boundary sample)
4-3	轴向间隙 Shaft end play	0.1mm~0.3mm	
4-4	振子固定力 Holding strength of vibration weight	49N (5kgf) Min	

5.性能特征/Performance and characteristics

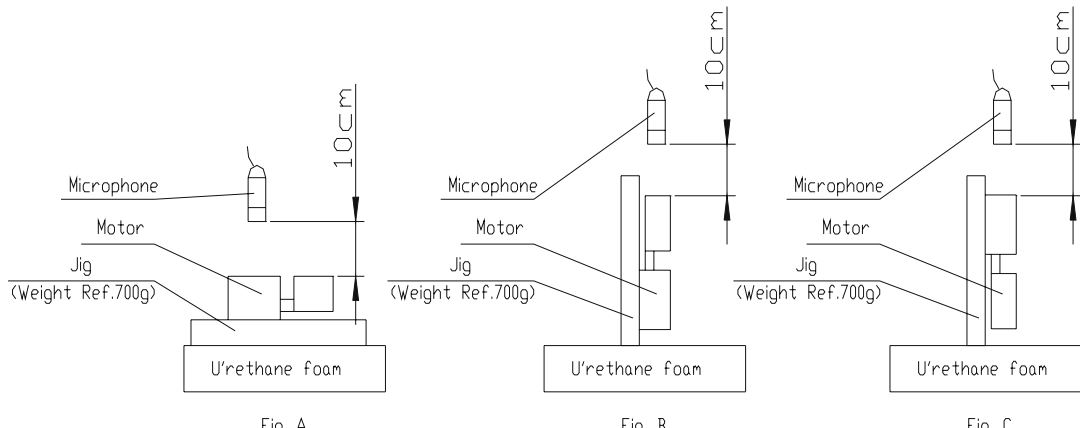
项目/Item	规格/Specifications	条件·备注/Conditions & Remarks
5-1 额定转速 Rated speed	8500±2000rpm	在额定电压和额定负载(振子)下。 At rated voltage and rated load (vibration weight).
5-2 额定电流 Rated current	90 mA Max	
5-3 堵转电流 Stall current	145 mA Max	在额定电压下 At rated voltage
5-4 起动电压 Starting voltage	0.75V DC Max	在额定负载(振子)下电枢的任意位置。 At rated load (Counterweight) any position of rotor.
5-5 绝缘电阻 Insulation resistance	1MΩ Min	在 100V 直流下, 端子和机壳间 At DC 100V between Terminal and case.
5-6 端子阻抗 Terminal resistance	11Ω (±20%)	在 20°C 下 At 20°C
5-7 机械噪音 Mechanical noise	50db(A) Max	<p>在额定电压、额定负载(振子)下 背景噪音: 不大于 28dB.A 计权 测试仪器: B&k 夹具重量: 700g At rated voltage and rated load (Counterweight). Back ground noise 28dB(A) Max Measuring instruments: B&k Weight of jig:700g</p> 

6. 可靠性/Reliability

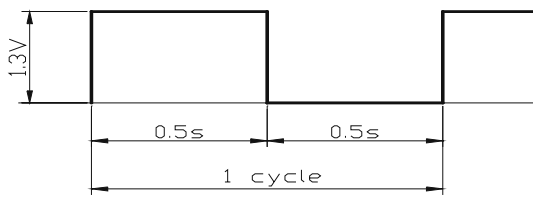
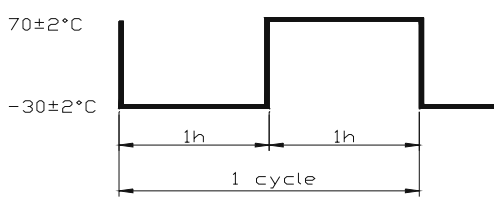
项目/Item	规格/Specification	判定标准/Judgment												
6-1 寿命 Life time	 <table border="1" data-bbox="359 571 997 750"> <tr> <td>位置 Position</td> <td>电压 Volt</td> <td>负荷 Load</td> <td>温度 Temp</td> <td>湿度 Humi</td> <td>寿命 Life</td> </tr> <tr> <td>轴水平 Horizon</td> <td>额定 额定</td> <td>重量 振子</td> <td>20℃</td> <td>65%</td> <td>200,000 Cycles</td> </tr> </table>	位置 Position	电压 Volt	负荷 Load	温度 Temp	湿度 Humi	寿命 Life	轴水平 Horizon	额定 额定	重量 振子	20℃	65%	200,000 Cycles	<p>在常温常湿下放置 2h 后，马达应符合项 7-1 的要求。</p> <p>After 2 hours exposure in ordinary temperature and humidity, Motors shall be approved as specified in item 7-1.</p>
位置 Position	电压 Volt	负荷 Load	温度 Temp	湿度 Humi	寿命 Life									
轴水平 Horizon	额定 额定	重量 振子	20℃	65%	200,000 Cycles									
6-2 低温放置 Low temp exposure	温度 /Temperature: $-40\pm 2^{\circ}\text{C}$ 时间 /Time: 96h	<p>在常温常湿下放置 2h 后，马达应符合项 7-2 的要求。</p> <p>After 2 hours exposure in ordinary temperature and humidity, Motors shall be approved as specified in item 7-2.</p>												
6-3 高温放置 High temp. Exposure	温度 /Temperature: $60\pm 2^{\circ}\text{C}$ 时间 /Time: 96h													
6-4 湿度放置 Humidity exposure	温度 /Temperature: $40\pm 2^{\circ}\text{C}$ 湿度 /Humidity: 90~95%RH 放置时间 /Exposure time: 96h 无水气凝结/No condensation of moisture													
6-5 振动 Vibration	频率 /Frequency: 10~55~10Hz 全振幅 /Displacement: 1.5mm (p-p) 加速度 /Acceleration: 22m/s^2 周期 /Period: 20min 完成 10~55~10Hz /20 Minutes log sweep 10~55~10Hz 方向 /Direction: x, y, z 时间 /Time: 每个方向 2h /Each 2 hours	<p>测试结果应符合项 7-2 的要求。</p> <p>After the test motors shall be approved as specified in item 7-2.</p>												
6-6 自然跌落 Free fall	试验状态/Test state:将马达固定在约 75 克（包括马达本身）的物体上，落向水泥地面。 Set the motor to the approximately 75g (include the motor) weight of block drop the motor on the concrete floor. 高度 /Height: 1.5m 方向 /Direction: 6 个面 / 6 faces 次数 /Number of times: 每个面 2 次 / Twice 2 each	<p>测试结果应符合项 7-2 的要求。</p> <p>After the test motors shall be approved as specified in item 7-2.</p>												
6-7 热冲击 Heat shock test	试验循环 /Test cycle :20 cycles 	<p>在常温常湿下放置 2h 后，马达应符合项 7-2 的要求。</p> <p>After 2 hours exposure in ordinary temperature and humidity, Motors shall be approved as specified in item 7-2.</p>												

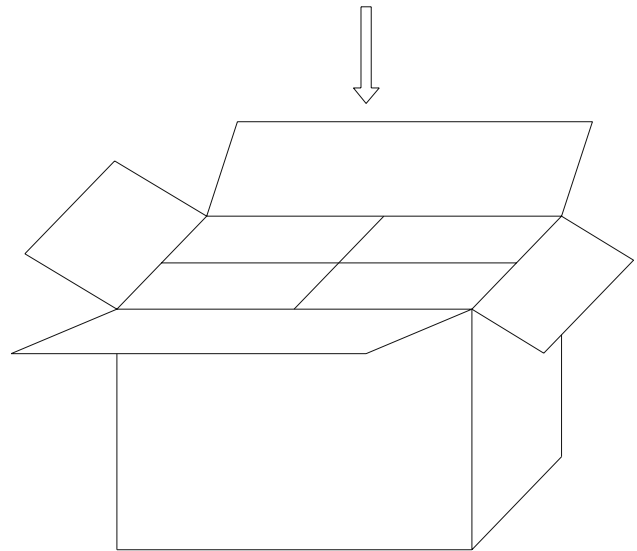
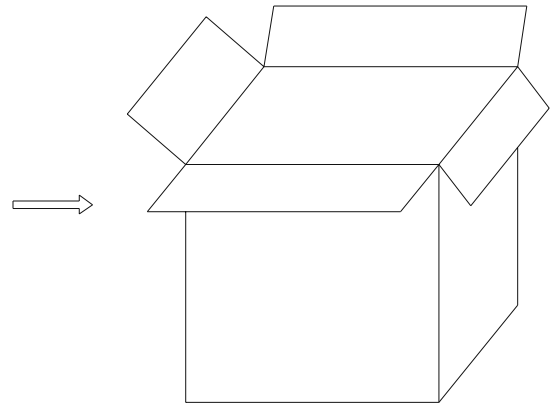
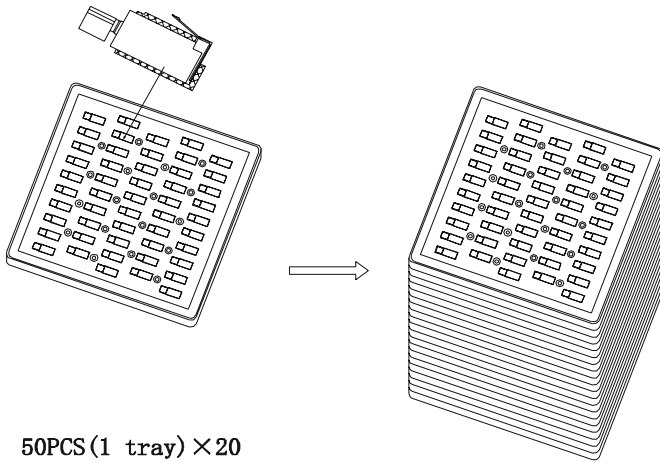
9. 包装/Packaging
**圆柱马达包装
Packaging drawing of cylindrical motor**

包装试验要求
1. 标准

- (1) 整箱重量小于等于9kg的，跌落高度设定为75cm.
- (2) 整箱重量大于9kg但小于等于23kg的，跌落高度设定为60cm.

2. 试验方法:

跌落要求为六面三棱一角.

- (1) 六面: 先从最大两面跌, 然后是中间大小的两面, 最后跌最小的两面, 一共六次.
- (2) 三棱: 指任选三条同一角的棱, 跌落秩序: 最长棱, 中间长度, 最短的, 一共三次.
- (3) 一角: 指上一步三条棱所组成的角, 跌落一次.

3. 判定基准

经过跌落试验后, 产品外观、性能无不良.

Package Test Requirement:
1. Criteria

- (1) The weight of the whole carton less than 9kg, the dropping height is 75cm.
- (2) The weight of the whole carton more than 9kg and less than 23kg, the dropping height is 60cm.

2. Test Methods:

Dropping requirement is 6 faces, 3 arris, 1 angle.

- (1) 6 faces: First dropping with two biggest faces, then dropping with another two middle faces, at last dropping with two smallest faces, once per face, total 6 faces.
- (2) 3 arris: Choose any 3 arris which make up of the same the angle, the dropping sequence is the longest arris, middle arris, shortest arris. Total 3 times.
- (3) 1 angle: Point to the angle which is made up with the 3 arris in the above step. Dropping for 1 time.

3. Judgement Criterion

After drop test, no evidence of damage on the appearance and performance.

Remarks:

4000PCS/CTN: 43cm × 21cm × 25.5cm

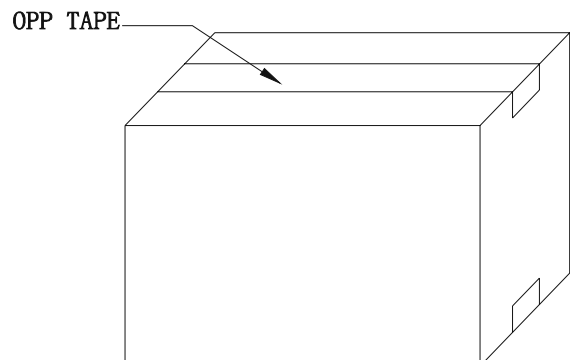

10. 外形图/Outline Drawing

PCB Land drawing

Technical Requirements:

1. 额定电压/Rated voltage: 1.3V
2. 额定电流/Rated current: 90mA Max
3. 额定转速/Rated speed: 8500 ± 2000rpm
4. 堵转电流/Stall current: 145mA Max
5. 端子阻抗/Terminal resistance: 11Ω(±20%)
6. 启动电压/Starting voltage: 0.75V Max
7. 轴向间隙/Shaft end play: 0.1~0.3mm
8. 所有尺寸为A向压紧后的尺寸(不包括轴向间隙)
Overall length is measured after counterweight being pressed against body in direction A. (Shaft end play is not included.)
9. 未注线性公差为/Unmarked tolerance: ± 0.1mm

C. W.

A向

Vybronic		外形图		VZ6SH1A0060711	
阶段标记	重量	比例		共 页	第 页
		5:1			
设计	郭梦秋	2010.04.03	标准化	日期	2010.04.03
校对	杨 兰	2010.04.03	签 名	项瑞莹	2010.04.03
审核	靳景海	2010.04.03	更改文件号	批准	2010.04.03
工艺	刘林兵	2010.04.03	分 区	批 准	2010.04.03
处 数	1	1	1	1	1

借 (通) 用件登记	
底图总号	
签 字	
日 期	

