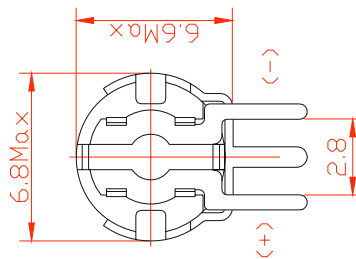
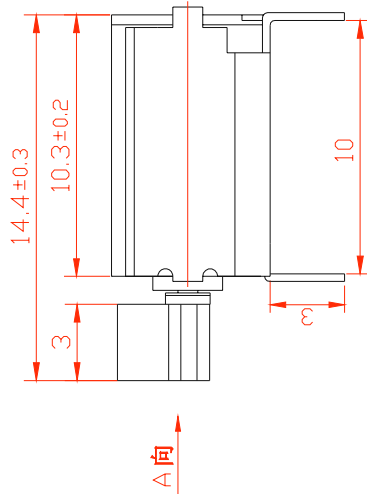
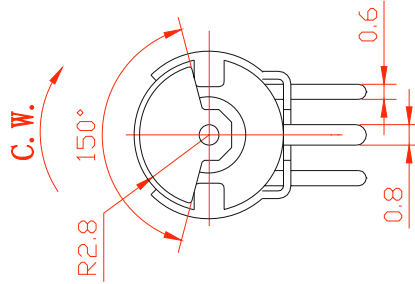

- 技术要求/Technic requirement**
1. 额定电压/Rated voltage: 3.0V
 2. 额定电流/Rated current: 70mA Max
 3. 额定转速/Rated speed: 10000 ± 2000rpm
 4. 堵转电流/Stall current: 105mA Max
 5. 端子阻抗/Terminal resistance: 35Ω (± 20%)
 6. 启动电压/Starting voltage: 1.7V Max
 7. 轴向间隙/Shaft end play: 0.1~0.3mm
 8. 所有尺寸为A向压紧后的尺寸(不包括轴向间隙)
/Overall length is measured after counterweight being pressed against body in direction A. (Shaft end play is not included.)
 9. 未注线性公差为/Unmarked tolerance: ± 0.1mm

Vybronic
外形图
VZ6SCAB0061141

设计	郭梦秋	2011.03.16	标准化	日期	
校对	杨兰	2011.03.16		签名	
审核	彭小华	2011.03.16	批准	项瑞登	2011.03.16
工艺					
阶段标记		重量	比例	共 页	
			5:1	第 页	

借(通) 用件登记

底图总号

签字

日期

11. 修改记录/Revision History

修改号 Rev. No.	日期 Rev. Date	页码 Page No.	修改项目 Revised Item	更改原因 Reason
A/0	2011.03.16	/	产品颁布/ Release for Production	
A/1	2020.07.01	/	changed company name from JINLONG MACHINERY to VYBRONICS, changed part # from Z6SCAB0061141 to VZ6SCAB0061141	Rebranding