



产品规格书

PRODUCT SPECIFICATION

客户名称Buyer Name	
客户料号Buyer Part No.	
客户承认签章 Buyers Approval & Signatures	

文件编号Spec No.		版本	A/2
品名描述 Product Description	圆柱直流马达 Cylindrical DC motor		
型号Part No.	VZ6DL2A0765217		
送样日期Date			
设计Designed by	审核Checked by	批准Approved by	
2020.10.02	2020.10.02	2020.10.02	

www.vybronic.com

sales@vybronic.com

规格书内容/Contents

1、适用范围/ General Scope	3/8
2、使用条件/ Operating Conditions	3/8
3、测定条件/ Measuring Conditions	3/8
4、机械要求/ Mechanical Specifications	3/8
5、性能特征/ Performance and characteristics	4/8
6、使用时注意事项/ Attentions	4/8
7、产品符合有害物质标准的要求/ Products meet the requirement of hazardous substances standard	4/8
8、外形图/ Outline Drawing	5/8
9、固定夹/ Metal Holder	6/8
10、塑料封盖/ Plastic Close Cover	7/8
11、修改记录/ Revision History	8/8

1. 适用范围/ General Scope

本说明书适用于圆筒式永磁直流电机 VZ6DL2A0765217 型

This specification applies to cylindrical permanent-magnetic motors DC model VZ6DL2A0765217

2. 使用条件/ Operating Conditions

项目/Item	规格/Specifications	条件·备注/Conditions & Remarks
2-1 额定电压 Rated voltage	1.3V DC	
2-2 额定负荷 Rated load	振子 Vibration weight	见外形图 As specified in outline drawing
2-3 旋转方向 Rotation	C.W (clockwise)	
2-4 马达位置 Motor position	全方位 All position	
2-5 使用电压范围 Operating voltage	0.9~1.6V DC	
2-6 使用环境 Operating environment	-30 ~ 70℃, 常湿 /Ordinary Humidity:65±20%RH	无水气凝结 No condensation of moisture
2-7 保存环境 Storage environment	-40 ~ 80℃, 常湿 /Ordinary Humidity:65±20%RH	无水气凝结 No condensation of moisture

3. 测定条件/ Measuring Conditions

项目/Item	规格/Specifications	条件·备注/Conditions & Remarks
3-1 温度 Temperature	20±2℃	
3-2 湿度 Humidity	(63%~67%) RH	
3-3 位置 Motor position	轴向水平 Motor shaft horizontal	将马达固定在试验台上 Lock the motor in a test fixture

标准测试条件为温度 20℃，湿度 65%。如无疑异，也可在温度 5~35℃、湿度 45~85% 的条件下测试。马达测试时，放置方向为轴向水平。/The measurement at 20℃ & 65%RH is standard. If the judgment is not questionable, recognize measurement at 5℃ to 35℃ & relative humidity 45% to 85%. Direction of motor is shaft horizontal.

4. 机械要求/ Mechanical Specifications

项目/Item	规格/Specifications	条件·备注/Conditions & Remarks
4-1 结构 Configuration	见外形图 As specified in outline drawing	Outline drawing No: VZ6DL2A0765217
4-2 外观 Appearance	不含有机机械损坏及不充分的浸蚀等。 There shall be no evidence of mechanical damage and shall not have inadequate corrosion and so on	目测（容许范围根据样品外形） Visual examination(allowable extent is based on boundary sample)
4-3 轴向间隙 Shaft end play	0.1mm~0.3mm	对单体马达的定义/Definition of monomer motor
4-4 振子固定力 Holding strength of vibration weight	49N (5kgf) Min	

5.性能特征/Performance and characteristics

项目/Item		规格/Specifications	条件·备注/Conditions & Remarks	
5-1	额定转速 Rated speed	10,000±2000 rpm	在额定电压和额定负载（振子）下。 At rated voltage and rated load (Counterweight).	单体马达测试 夹具夹紧力大约为 10N。 /Clamp force of motor test is approximate 10N
5-2	额定电流 Rated current	250 mA Max		
5-3	起动电压 Starting voltage	0.75V DC Max	在额定负载（振子）下电枢的任意位置。 At rated load (Counterweight) any position of rotor.	
5-4	绝缘电阻 Insulation resistance	1MΩ Min	在 100V 直流下，端子和机壳间 At DC 100V between Terminal and case.	
5-5	端子阻抗 Terminal resistance	3.6Ω (± 20%)	在 20°C 下 At 20°C	

6.使用时注意事项/Matters to be paid attention to when using motor

6-1 电机在运输过程中应小心轻放，避免严重碰撞敲击引起的电机机身和性能受损。（Please lay the motors carefully in transportation to avoid any serious damage to the motor body or its electric function because of collision.）

6-2 请按照规格书中规定的第 2 条(使用条件)来使用和存储电机，否则会影响电机性能。（Please use and storage motors according to N0.2 item (Operating Conditions) in specification, or else motor characteristics would be affected.）

6-3 在使用和打开马达外包装时请避免水气凝结。（Condensation of atmosphere must be avoided in motor usage or opening the packaging of the motor.）

6-4 马达应适当的操作、储存和运转环境中均不可存在腐蚀性气体。例如：H₂S、SO₂、NO₂、CL₂等。另外存储环境中不可有诸如硅、氰、甲醛水和苯酚等能放射出腐蚀性气体的物质，在电机的机械构造或装置中，如果存在腐蚀性气体，那么这会起引起马达不运转。（For proper operation. storage and operating environment must not contain corrosive gases. For example H₂S. SO₂. NO₂. CL₂. etc. In addition storage environment must not have materials that emit corrosive gases especially from silicon. cyanic. formalin and phenol group. In the mechanism or the set. existence of corrosive gases may cause no rotation in motor.）

7.产品符合 ROHS 及 Vybronic 有害物质含量标准的要求。

The product is accord with the ROHS requirement and the requirement of hazardous substances content standard in Vybronic.

序号 /NO.	禁用物质名称 /forbidden substances name	最大含量标准 PPM 或 mg/kg Most content criterion PPM or mg/kg
1	铅及其化合物/ Pb and compounds	≤1000PPM * <0.35%钢合金 * <4%铜合金
2	镉及其化合物/ Cadmium and compounds	≤100PPM
3	六价铬/ Cr VI	≤1000PPM
4	汞及其化合物/ Mercury and compounds	≤1000PPM
5	聚溴化苯/ PBBs,poly brominated biphenyl	≤1000PPM
6	聚溴化苯醚/ PBDEs,poly brominated biphenyl ethers	≤1000PPM

技术要求/Technical Requirements

1. 额定电压/Rated voltage:1.3V
2. 额定电流/Rated current:250mA Max
3. 额定转速/Rated speed:10000 ± 2000rpm
4. 端子阻抗/Terminal resistance:3.6Ω(±20%)
5. 启动电压/Starting voltage:0.75V Max
6. 轴向间隙/Shaft end play:0.1~0.3mm
7. 导线规格/Lead wire spec:AWG30 UL1571
8. 焊锡拉力/Pull to break the tin soldering places:≥10N
9. 未注线性公差为/Unmarked tolerance: ± 0.1mm

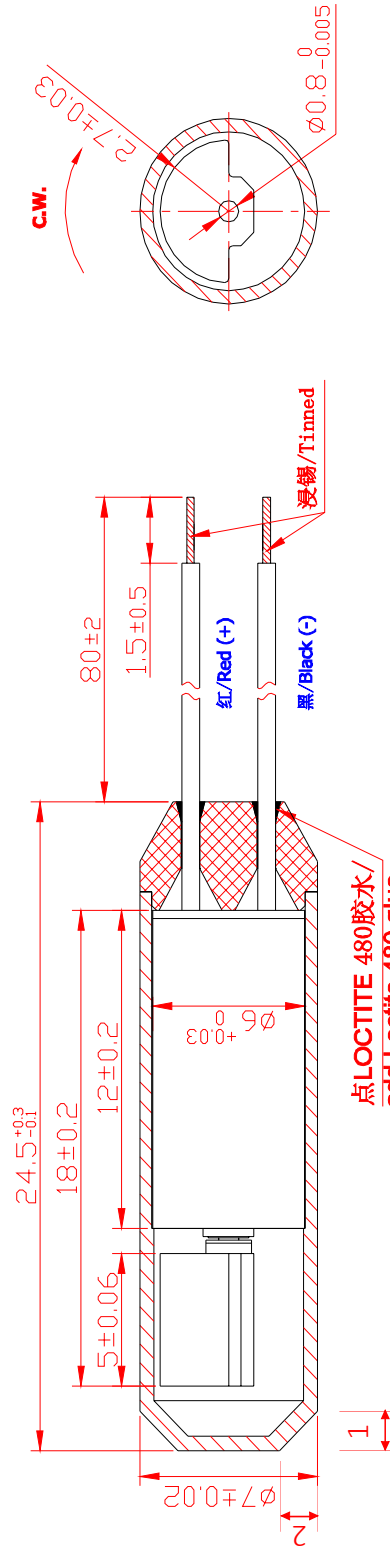

借(通)用件登记

底图总号

签字

日期

Vybronic		外形图		VZ6DL2A0765217	
设计	郭梦秋	10.11.09	标准化	阶段标记	重量
校对	杨至	10.11.09			比例
审核	彭小平	10.11.09			4:1
工艺	刘林兵	10.11.09	批准	共 页	第 页
			项瑞莹	10.11.09	
			签名	日期	
			更改文件号		

- 技术要求**
- 1.未注内圆角R0.1
 - 2.表面光滑、无毛刺
 - 3.未注尺寸公差按GB/T1804-m级
 - 4.颜色：白色

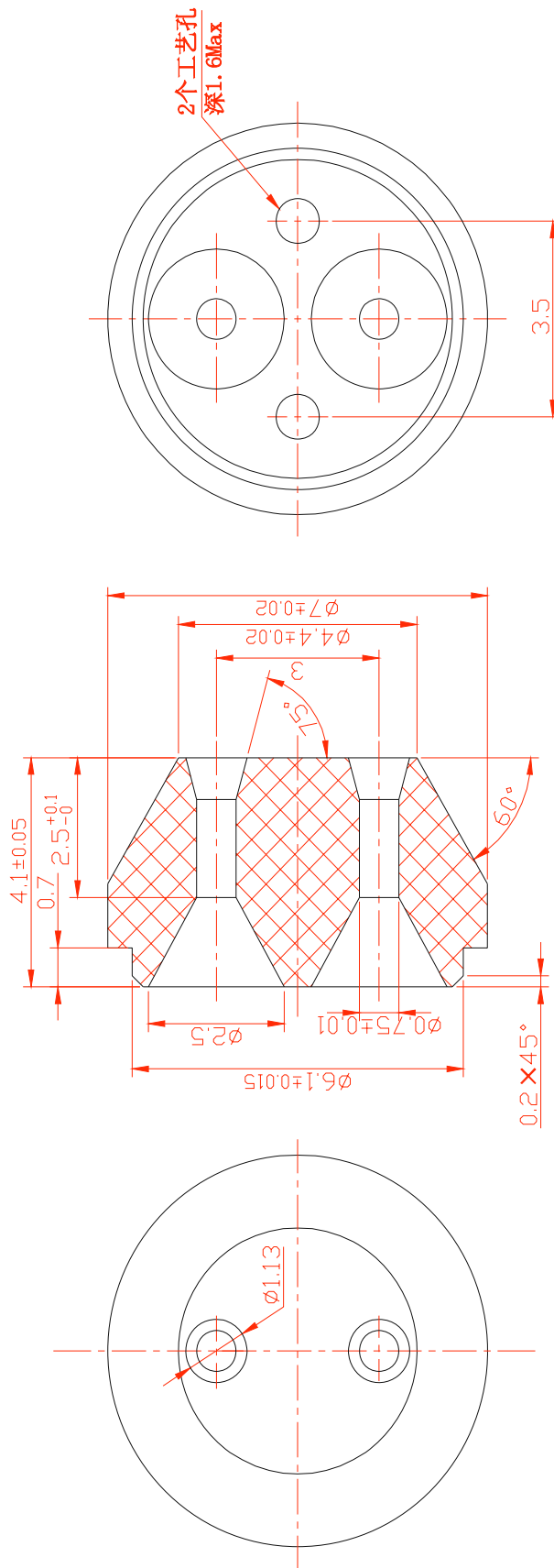

借(通)用件登记

描图

描校

底图总号

签字

张爱平

日期

060304

VybronicS		塑料封盖	
阶段	标记	重量	比例
			10:1
共 5 页		第 5 页	
日期	签名	更改文件号	标准
			批准
标记	处数	分区	工艺
设计	校对	审核	工艺

