



产品规格书

PRODUCT SPECIFICATION

客户名称Buyer Name	
客户料号Buyer Part No.	
客户承认签章 Buyers Approval & Signatures	

文件编号Spec No.		版本	A/1
品名描述 Product Description	圆柱直流马达 Cylindrical DC motor		
型号Part No.	VZ4TL2B124064X		
送样日期Date			
设计Designed by	审核Checked by	批准Approved by	
2020.07.01	2020.07.01	2020.07.01	

www.vybronic.com
sales@vybronic.com

规格书内容/Contents

1、适用范围/ General Scope	3/9
2、使用条件/ Operating Conditions	3/9
3、测定条件/ Measuring Conditions	3/9
4、机械要求/ Mechanical Specifications	3/9
5、性能特征/ Performance and characteristics	4/9
6、可靠性/ Reliability	5/9
7、要求/ Requirements	6/9
8、使用时注意事项/ Attentions	6/9
9、包装/ Packaging	7/9
10、外形图/ Outline Drawing	8/9
11、修改记录/ Revision History	9/9

1. 适用范围/ General Scope

本规格书适用于圆筒式永磁直流电机 VZ4TL2B124064X 型

This specification applies to cylindrical permanent-magnetic motors DC model VZ4TL2B124064X

2. 使用条件/Operating Conditions

项目/Item		规格/Specifications	条件·备注/Conditions & Remarks
2-1	额定电压 Rated voltage	3.0V DC	
2-2	额定负荷 Rated load	振子 Counterweight	见 10. 外形图 As specified in 10. Outline Drawing
2-3	旋转方向 Rotation	C.W/C.C.W (clockwise or counter clockwise)	
2-4	马达位置 Motor position	全方位 All position	
2-5	使用电压范围 Operating voltage	2.2~3.6V DC	
2-6	使用环境 Operating environment	-30 ~ 70℃, 常湿 /Ordinary Humidity:65±20%RH	无水气凝结 No condensation of moisture
2-7	保存环境 Storage environment	-40 ~ 80℃, 常湿 /Ordinary Humidity:65±20%RH	无水气凝结 No condensation of moisture

3. 测定条件/Measuring Conditions

项目/Item		规格/Specifications	条件·备注/Conditions & Remarks
3-1	温度 Temperature	20±2℃	
3-2	湿度 Humidity	(63%~67%) RH	
3-3	位置 Motor position	轴向水平 Motor shaft horizontal	将马达固定在试验台上 Lock the motor in a test fixture

标准测试条件为温度 20℃, 湿度 65%。如无疑异, 也可在温度 5~35℃、湿度 45~85% 的条件下测试。马达测试时, 放置方向为轴向水平。/The measurement at 20℃ & 65%RH is standard. If the judgment is not questionable, recognize measurement at 5℃ to 35℃ & relative humidity 45% to 85%. Direction of motor is shaft horizontal.

4. 机械要求/Mechanical Specifications

项目/Item		规格/Specifications	条件·备注/Conditions & Remarks
4-1	结构 Configuration	见外形图 As specified in outline drawing	Outline drawing No: VZ4TL2B124064X
4-2	外观 Appearance	不含有机械损坏及不适当的浸蚀等。 There shall be no evidence of mechanical damage and shall not have inadequate corrosion and so on	目测 (容许范围根据样品外形) Visual examination(allowable extent is based on boundary sample)
4-3	轴向间隙 Shaft end play	0.05mm~0.2mm	
4-4	振子固定力 Holding strength of vibration weight	30N (3kgf) Min	

5.性能特征/Performance and characteristics

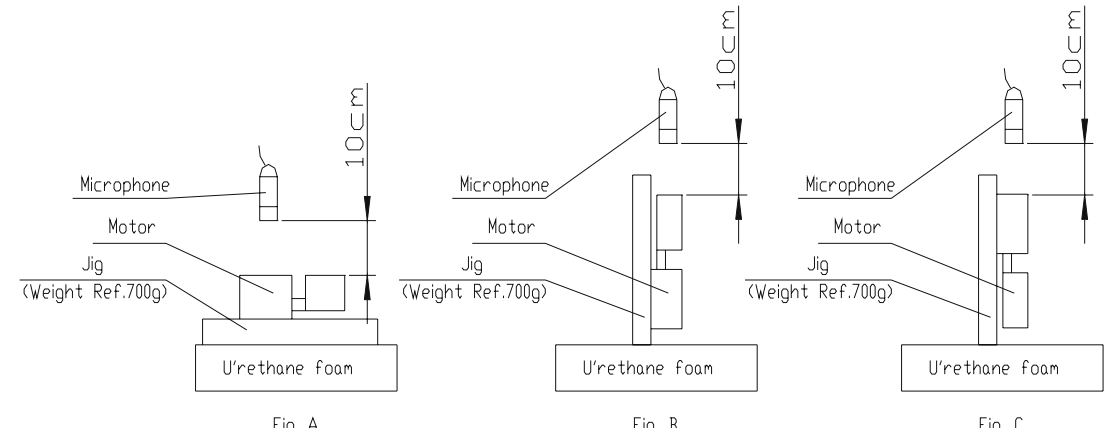
项目/Item	规格/ Specifications	条件·备注/ Conditions & Remarks
5-1 额定转速 Rated speed	15,000±2500 rpm	在额定电压和额定负载（振子）下。 At rated voltage and rated load (Counterweight).
5-2 额定电流 Rated current	80 mA Max	
5-3 堵转电流 Stall current	105 mA Max	在额定电压下。 At rated voltage
5-4 起动电压 Starting voltage	2.0V DC Max	在额定负载（振子）下电枢的任意位置。 At rated load (Counterweight) any position of rotor.
5-5 绝缘电阻 Insulation resistance	1MΩ Min	在 100V 直流下，端子和机壳间 At DC 100V between Terminal and case.
5-6 端子阻抗 Terminal resistance	35Ω (±20%)	在 20°C 下 At 20°C
5-7 机械噪音 Mechanical noise	50dB(A)Max	<p>在额定电压、额定负载（振子）下 背景噪音：不大于 28dB.A 计权 测试仪器：B&k 夹具重量：700g At rated voltage and rated load (Counterweight). Back ground noise 28dB(A) Max Measuring instruments: B&k Weight of jig:700g</p> 

6. 可靠性/Reliability

项目/Item	规格/ Specifications	判定标准/Judgment												
6-1 寿命 Life time		试验后, 马达应符合项 7-1 的要求。 After the test, motors shall be approved as specified in item 7-1.												
	<table border="1"> <tr> <td>位置 Position</td> <td>电压 Volt</td> <td>负荷 Load</td> <td>温度 Temp</td> <td>湿度 Humi</td> <td>寿命 Life</td> </tr> <tr> <td>轴水平 Horizon</td> <td>额定 Rated</td> <td>振子 Weight</td> <td>20°C</td> <td>65%</td> <td>200,000 Cycles</td> </tr> </table>		位置 Position	电压 Volt	负荷 Load	温度 Temp	湿度 Humi	寿命 Life	轴水平 Horizon	额定 Rated	振子 Weight	20°C	65%	200,000 Cycles
	位置 Position		电压 Volt	负荷 Load	温度 Temp	湿度 Humi	寿命 Life							
轴水平 Horizon	额定 Rated	振子 Weight	20°C	65%	200,000 Cycles									
低温放置 Low temp exposure	温度 /Temperature: $-40\pm 2^{\circ}\text{C}$ 时间 /Time: 96h													
6-3 高温放置 High temp. Exposure	温度 /Temperature: $80\pm 2^{\circ}\text{C}$ 时间 /Time: 96h	在常温常湿下放置 2h 后, 马达应符合项 7-2 的要求。 After 2 hours exposure in ordinary temperature and humidity, Motors shall be approved as specified in item 7-2.												
6-4 湿度放置 Humidity exposure	温度 /Temperature: $40\pm 2^{\circ}\text{C}$ 湿度 /Humidity: 90~95%RH 放置时间 /Exposure time: 96h 无水气凝结/No condensation of moisture													
6-5 振动 Vibration	全振幅 /Displacement: 1.5mm (p-p) 频率 /Frequency: 10 ~ 55Hz 加速度 /Acceleration: 22m/s^2 周期 /Period: 20min 完成 10~55~10Hz /20 Minutes log sweep 10~55~10Hz 方向 /Direction: x, y, z 时间 /Time: 每个方向 2h /Each 2 hours													
6-6 自然跌落 Free fall	试验状态/Test state: 将马达固定在约 100 克 (包括马达本身) 的物体上, 落向水泥地面。 Set the motor to the approximately 100g (include the motor) weight of block drop the motor on the concrete floor. 高度 /Height: 1.5m 方向 /Direction: 6 个面 / 6 faces 次数 /Number of times: 每个面 2 次 / Twice 2 each	测试结果应符合项 7-2 的要求。 After the test motors shall be approved as specified in item 7-2.												
6-7 热冲击 Heat shock test	试验循环 /Test cycle :20 cycles 	在常温常湿下放置 2h 后, 马达应符合项 7-2 的要求。 After 2 hours exposure in ordinary temperature and humidity, Motors shall be approved as specified in item 7-2.												

9. 包装/Packaging

圆柱马达包装 Packaging drawing of cylindrical motor

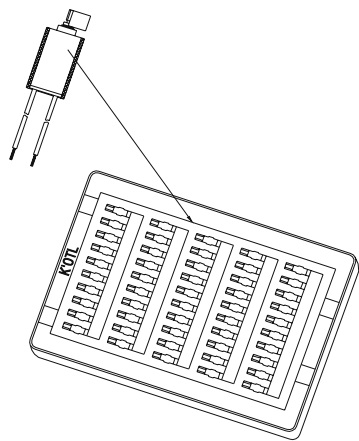

50PCS (1 tray) × 20

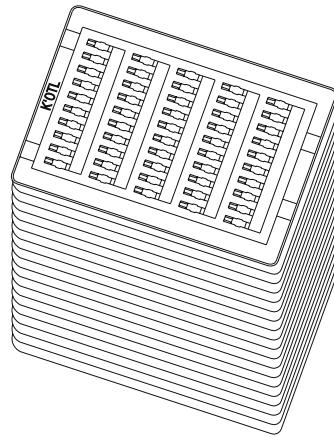

1000PCS (1 bundle) × 6

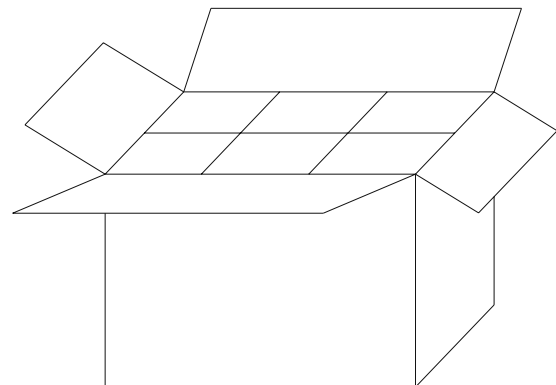
包装试验要求
1. 标准

- (1) 整箱重量小于等于9kg的, 跌落高度设定为75cm.
- (2) 整箱重量大于9kg但小于等于23kg的, 跌落高度设定为60cm.

2. 试验方法:

跌落要求为六面三棱一角.

- (1) 六面: 先从最大两面跌, 然后是中间大小的两面, 最后跌最小的两面, 一共六次.
- (2) 三棱: 指任选三条同一角的棱, 跌落秩序: 最长棱, 中间长度, 最短的, 一共三次.
- (3) 一角: 指上一步三条棱所组成的角, 跌落一次.

3. 判定基准

经过跌落试验后, 产品外观、性能无不良.

Package Test Requirement:
1. Criteria

- (1) The weight of the whole carton less than 9kg, the dropping height is 75cm.
- (2) The weight of the whole carton more than 9kg and less than 23kg, the dropping height is 60cm.

2. Test Methods:

Dropping requirement is 6 faces, 3 arris, 1 angle.

- (1) 6 faces: First dropping with two biggest faces, then dropping with another two middle faces, at last dropping with two smallest faces, once per face, total 6 faces.
- (2) 3 arris: Choose any 3 arris which make up of the same the angle, the dropping sequence is the longest arris, middle arris, shortest arris. Total 3 times.
- (3) 1 angle: Point to the angle which is made up with the 3 arris in the above step. Dropping for 1 time.

3. Judgement Criterion

After drop test, no evidence of damage on the appearance and performance.

Remarks:

- 1000PCS/CTN: 23.5cm × 17cm × 27cm
- 2000PCS/CTN: 33.5cm × 23.5cm × 27cm
- 4000PCS/CTN: 46.5cm × 33.5cm × 27cm
- 6000PCS/CTN: 50.5cm × 46.5cm × 27cm

OPP TAPE

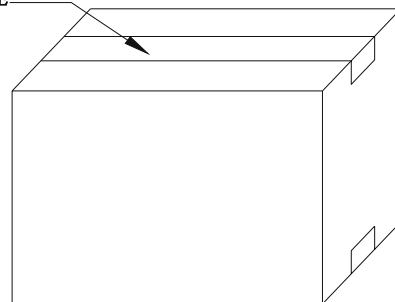

10. 外形图/Outline Drawing

- 技术要求/Technical requirement
1. 额定电压/Rated voltage: 3.0V
 2. 额定电流/Rated current: 80mA Max
 3. 额定转速/Rated speed: 15000 ± 2500rpm
 4. 堵转电流/Stall current: 105mA Max
 5. 端子阻抗/Terminal resistance: 35Ω (±20%)
 6. 启动电压/Starting voltage: 2.0V Max
 7. 轴向间隙/Shaft end play: 0.05~0.2mm
 8. 导线规格/Lead wire spec: AWG32 UL3302
 9. 所有尺寸为A向压紧后的尺寸(不包括轴向间隙)
/Overall length is measured after counterweight being pressed against body in direction A. (Shaft end play is not included.)
 10. 未注线性公差为/Unmarked tolerance: ± 0.1mm

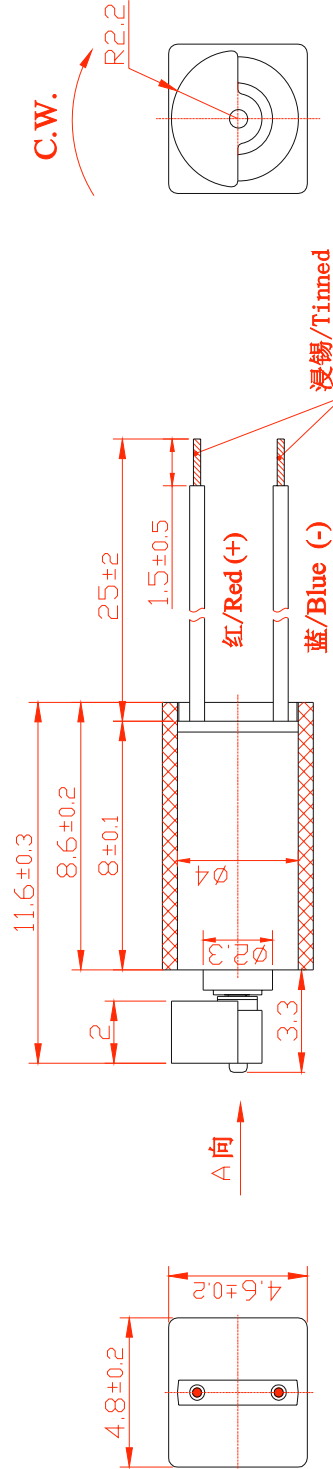

Vybronic		外形图		VZ4TL2B124064X	
标志	处数	分区	更改文件号	签名	日期
设计	郭梦秋	2009.05.15	标准化	张其荣	2009.05.15
校对	杨兰	2009.05.15			
审核	陈文荣	2009.05.15			
工艺	刘林兵	2009.05.15	批准	项瑞坚	2009.05.15
阶段标记			重量	比例	
共 页			5:1	第 页	

借(通)用件登记
底图总号
签字
日期

