



# 产品规格书

PRODUCT SPECIFICATION

|  |  |
|--|--|
| 客户名称Buyer Name                         |  |
| 客户料号Buyer Part No.                     |  |
| 客户承认签章<br>Buyers Approval & Signatures |  |

|                             |  |               |     |
|-----------------------------|--|---------------|-----|
| 文件编号Spec No.                |  | 版本            | A/2 |
| 品名描述<br>Product Description | 圆柱铁芯贴片马达<br>Cylindrical core SMT Motor |               |     |
| 型号Part No.                  | VZ43FM1B8230001L                       |               |     |
| 送样日期Date                    |  |               |     |
| 设计Designed by               | 审核Checked by                           | 批准Approved by |     |
|                             |  |               |     |
| 2020.12.01                  | 2020.12.01                             | 2020.12.01    |     |

[www.vybronic.com](http://www.vybronic.com)

[sales@vybronic.com](mailto:sales@vybronic.com)

## - 目录/List -

|                                      |       |
|--------------------------------------|-------|
| 封面/Cover                             | 1/19  |
| 目录/Contents                          | 2/19  |
| 更改记录/Records of Revision             | 3/19  |
| 1. 结构形式/Construction Form            | 4/19  |
| 2. 使用条件/Standard operating condition | 4/19  |
| 3. 测试条件/Testing Condition            | 5/19  |
| 4. 贮存环境/Storage Environment          | 5/19  |
| 5. 电气特性/Electrical Characteristics   | 5/19  |
| 6. 机械特性/Mechanical Characteristics   | 7/19  |
| 7. 可靠性试验/Reliability Test            | 9/19  |
| 8. 寿命试验/Life Test                    | 11/19 |
| MTBF, FIT 测试/MTBF, FIT Test          | 12/19 |
| 9. 环保要求/Environment Protections      | 13/19 |
| 10. 注意事项/Caution                     | 15/19 |
| 11. 外形图/Outside View                 | 16/19 |
| 12. 结构图及物料清单/Structure Drawing & BOM | 17/19 |
| 13. 包装要求/Packaging Requirement       | 18/19 |
| 14. 回流老化曲线/Reflow Specification      | 19/19 |



**1. 结构形式/Construction Form**

本规格书适用于移动电话的振动马达。

This datasheet is stipulated for vibration motor for mobile phone.

| NO. | 项目/Item                       | 规格/Specifications                            |
|-----|-------------------------------|--|
| 1-1 | 电机结构<br>Motor construction    | Φ4.1 圆柱形铁芯直流电机<br>Φ4.1 DC Cored motor        |
| 1-2 | 换向片数<br>Number of phases      | 3 组换向片<br>3-phases                           |
| 1-3 | 磁极数<br>Number of magnet poles | 两极 (外置磁极型式)<br>2-poles (Inner magnet type)   |
| 1-4 | 线圈<br>Coil construction       | 铁芯线圈<br>Iron-cored coil                      |
| 1-5 | 整流技术<br>Rectifying method     | 采用高精度电刷和换向器<br>Precious brush and commutator |

**2. 使用条件/Standard Operating Condition**

| NO. | 项目/Item                               | 规格/Specifications |
|-----|---------------------------------------|-------------------|
| 2-1 | 额定电压<br>Rated voltage                 | DC3.0V            |
| 2-2 | 使用电压范围<br>Operating voltage range     | DC 2.3~3.6V       |
| 2-3 | 旋转方向<br>Rotating direction            | CW / CCW          |
| 2-4 | 使用温度范围<br>Operating temperature range | -30℃~+70℃         |

**3.测试条件/Testing Condition**

| NO. | 项目/Item                              | 规格/Specifications                               |
|-----|--------------------------------------|---|
| 3-1 | 温度<br>Temperature                    | 20°C ±2   |
| 3-2 | 湿度<br>Humidity                       | 45% ~85%RH                                      |
| 3-3 | 电源电压<br>Power supply, voltage source | 直流电源或电池 3.0V<br>DC power supply or battery 3.0V |
| 3-4 | 马达安放状态<br>Posture of motor           | 水平/Horizontal                                   |

**4.贮存环境/Storage Environment**

| NO. | 项目/Item                   | 规格/Specifications                                 |
|-----|---------------------------|---|
| 4-1 | 贮存温度<br>Storage temp      | -40°C ~+85°C                                      |
| 4-2 | 相对湿度<br>Relative humidity | 5%~95%<br>(No condensation of moisture/无水汽<br>凝结) |

**5.电气特性/Electrical Characteristic**

| NO. | 项目/Item                  | 单位<br>/Unit | 规格/Spec.     | 条件/Condition  |
|-----|--------------------------|-------------|--------------|---|
| 5-1 | 额定转速<br>Rated speed      | rpm         | 12000 ± 2500 | 额定电压:DC 3.0V<br>Rated voltage:DC 3.0V   |
| 5-2 | 额定电流<br>Rated current    | mA          | 85 Max       | 在额定电压和额定负载下测试<br>/Measure at rated voltage and<br>rated load  |
| 5-3 | 启动电流<br>Starting current | mA          | 100 Max      | 在额定电压下锁定振动轮, 测电机<br>电流 (2/3R 极端电阻处, 不在电刷<br>和整流子两点接触的位置)/Measure<br>current at locked counter weight ( R2.1<br>×3.0) in rated voltage(2/3R R:1<br>extreme resisting rate,Not in the<br>position when the brushes contact the<br>commutator at the two contact points) |

|     |                               |            |                         |  |
|-----|-------------------------------|------------|-------------------------|--|
| 5-4 | 启动电压<br>Starting voltage      | V          | 2.3 Max                 | DC2.3V电压下，开/关为1个循环，共3个循环<br>On/off-1cycle,total 3cycles under DC 2.3V                  |
| 5-5 | 端子阻抗<br>Terminal resistance   | $\Omega$   | 单相<br>1phase:33 $\pm$ 5 | 正极和负极之间<br>Between positive and negative   |
| 5-6 | 绝缘电阻<br>Insulation resistance | M $\Omega$ | 10Min                   | 测量机壳和引线之间。<br>测试电压直流100V。<br>Measuring between case and lead wire.Test voltage DC 100V |

**6. 机械特性/Mechanical Characteristics**

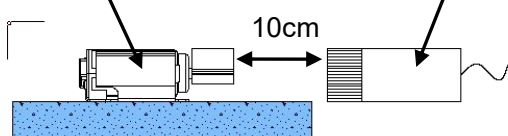
| NO  | 项目/Item                      | 单位/Unit | 规格/Spec.                    | 条件/Condition   |
|-----|------------------------------|---------|-----------------------------|--|
| 6-1 | 外观<br>Appearance             | /       |                             | 目测/Visual  |
| 6-2 | 尺寸<br>Size                   | mm      | 见外形图/See outline of drawing | 使用游标卡尺和千分尺测量/Use vernier caliper and micrometer to measure   |
| 6-3 | 马达重量<br>Motor Weight         | g       | 0.7±0.2g                    | 使用天平测量/Use scale   |
| 6-4 | 轴抗拉强度<br>Shaft pull strength | Kgf     | 5 MIN                       | 沿轴向施加拉力，保持 5 秒钟。/Pull shall be applied along with direction for 5s.  |
| 6-5 | 机械噪音<br>Mechanical Noise     | dB      | 50 MAX                      | <p>振动马达<br/>Vibration motor</p> <p>拾音器 microphone</p>  <p>10cm</p> <p>测试夹具<br/>Testing Jig</p> <p>马达：被固定/Motor : be fixed<br/>           额定电压:DC 3.0V/Rated voltage : DC 3.0 V<br/>           背景噪音： 25dB MAX.<br/> <b>Back ground noise: 25dB MAX.</b><br/>           拾音器沿轴向正对电机平面<br/> <b>Microphone faces the plane of motor along the shaft</b></p> |

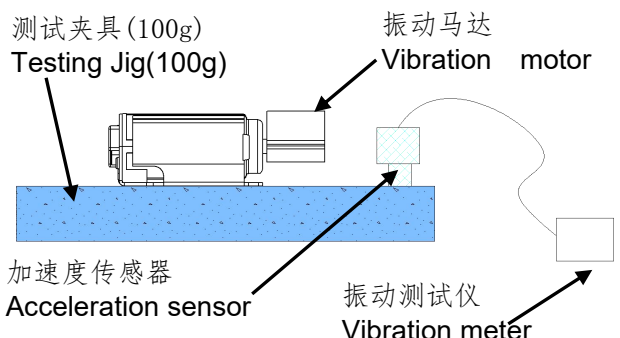
|     |                           |      |          |  |
|-----|---------------------------|------|----------|--|
| 6-6 | 振动量<br>Vibration Strength | Grms | 0.6 MIN  |  <p>测试夹具 (100g)<br/>Testing Jig(100g)</p> <p>振动马达<br/>Vibration motor</p> <p>加速度传感器<br/>Acceleration sensor</p> <p>振动测试仪<br/>Vibration meter</p> <p>马达: 被固定/Motor: be fixed.<br/>额定电压: DC 3.0V/Rated voltage : DC 3.0V .</p> |
|     |                           | Gp   | 0.84 MIN |  |
| 6-7 | 响应时间<br>Responsive Time   | ms   | 65       | 30ms 达到 50%振感,65ms 达到 100% 振感/<br>Motor vibration sense reach to 50% within 30ms,and 100% within 65ms.   |

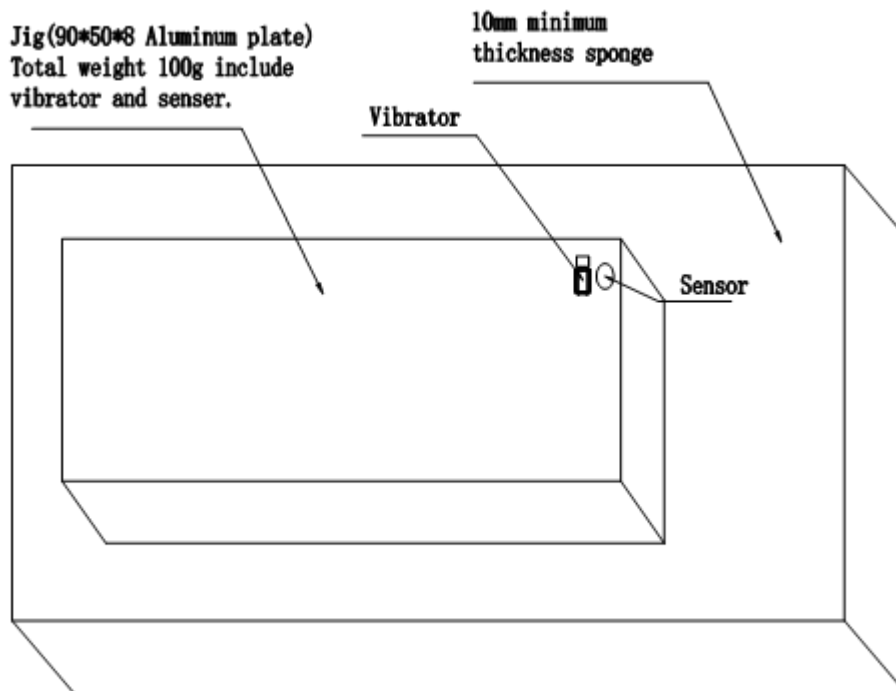

Simulation Vibration test method

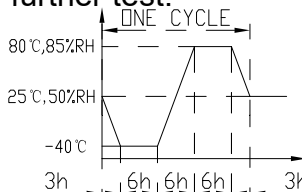

**7. 可靠性试验/Reliability Test**

| NO  | 项目/Item                                 | 条件/Condition  |
|-----|---|---|
| 7-1 | 高温贮存试验<br>High temperature storage test | 在+80℃的环境下放置96小时，然后在常温常湿下恢复4小时后测试。<br>Exposed at +80℃ for 96hours, then return to normal temperature and humidity for 4 hours before test.   |
| 7-2 | 低温贮存试验<br>Low temperature storage test  | 在-40℃的环境下放置96小时，然后在常温常湿下恢复4小时后测试。<br>Exposed at -40℃ for 96hours, then return to normal temperature and humidity for 4 hours before test.   |
| 7-3 | 湿热试验<br>Humidity test                   | 在温度 40℃，湿度 90%的环境下放置 48 小时，然后在常态下放置 4 小时后测试。/Expose the motor under the environment of 40℃,90%HR for 48 hours,then place the motor at normal temperature for 4 hours until further test.  |
| 7-4 | 高低温试验<br>Heat cycle test                | 确保电机在下图所示的条件下放置一个周期(马达表面避免有水汽凝结)，然后在室温下恢复4小时后，进行测试。/Assure the motor be placed under below testing conditions for one cycle(no condensation of moisture is allowed on the surface of motor), then put the motor at normal temperature for 4 hours until further test.<br>   |
| 7-5 | 振动试验<br>Vibration test                  | 将马达固定在100g的塑料夹具上，按以下要求进行试验：<br>1)振频范围:10-55Hz<br>2)全振幅1.5mm<br>3)振频变化10-55-10 约10分钟<br>4)振动方向:三个垂直方向<br>5)持续时间:每个方向10分钟（共30分钟）<br>Fix the motor on a 100g jig (plastic housing),and then make test according to below requirements:<br>1)Vibration frequency range: 10~55Hz<br>2)Total amplitude: 1.5mm<br>3)Sweep ratio: 10~55~10Hz approximate 10min<br>4)Direction of vibration: Three perpendicular directions<br>5)Duration: 10min(30min in total) |

|     |                         |  |
|-----|-------------------------|--|
| 7-6 | 跌落试验<br>Drop test       | 将马达电机放在大约60g（包括电机）重的物体上,从1.5米的高度跌落到20mm厚的硬木板上，跌落18次。/Set the motor to a fixture of approx.60g(include the motor) and drop it freely from the height of 1.5 meters to the hard wood board of 20mm thick, repeat dropping for 18 times.<br>高度/Height：1.5m 方向/Direction：±X，±Y，±Z<br>次数/Times：每一平面下落3次，共计18次/Three drops per plane for a total of 18 drops.  |
| 7-7 | 盐雾试验<br>Salt spray test | 电机放置盐雾试验箱，试验箱内湿度35%，盐溶液浓度5±1%；PH值为6.5-7.2；盐雾沉降量为1-2ml/80cm；浓度为5%的中性盐溶液中24小时。持续期满，清洗试验样品表面，用干净的棉布擦拭后进行检测，要求马达外观、振动功能良好，表面无腐蚀现象。<br>Put the motor in the salt spray test box for 24 hours, the humidity in the test case should be 35%, concentration of salt solution be 5± 1 %, PH value be 6.5-7.2, the precipitation of salt fog be 1-2ml/80cm, and the neutral salt solution should be with a concentration of 5%. At the end of the period, clean the surface of the tested sample, and then do further test once wiped with a clean cotton cloth. The appearance and vibrating function of the motor are required to be in good condition, and the surface should be free of corrosion. |

► 判定标准/Judgment standard

① 试验后，测试数据必须符合以下规格：

After test, measured data must be satisfied as following specifications;

- 启动电压: DC2.3V MAX.
- Starting voltage: DC2.3V MAX.
- 额定转速: 变化率在初始值的+30%~-20%以内。
- Rated speed: changing rate must be within +30%~-20% of initial value.
- 额定电流: 变化率在初始值的+20%~-30%以内。
- Rated current: changing rate must be within +20%~-30% of initial value.
- 端子阻抗: 变化率在初始值的±15%以内。
- Terminal resistance: changing rate must be within ±15% of initial value.

② 外形结构无异常。

There should be no abnormalities in appearance and structure.

**8.寿命试验/Life Test**

输入3.0V电压/Input voltage 3.0V.

带负载重量 (R1.8, t4.0大约0.4g) /Load counter weight (R1.8, t4.0 appx0.4g).

| NO  | 项目/Item  | 条件/Condition   |
|-----|--|--|
| 8-1 | 常温寿命试验<br>/Room Temperature<br>Life Test         | 放置在室温25°C, 50%RH的湿度条件下/ Exposure at room temperature of 25°C, and humidity of 50%RH. |
| 8-2 | 高温寿命试验/High<br>temperature<br>Exposure Life Test | 放置在高温55°C的条件下/Exposure at high temperature of 55°C.                                  |
| 8-3 | 低温寿命试验 /Low<br>temperature<br>Exposure Life Test | 放置在高温-20°C的条件下/Exposure at low temperature of -20°C.                                 |

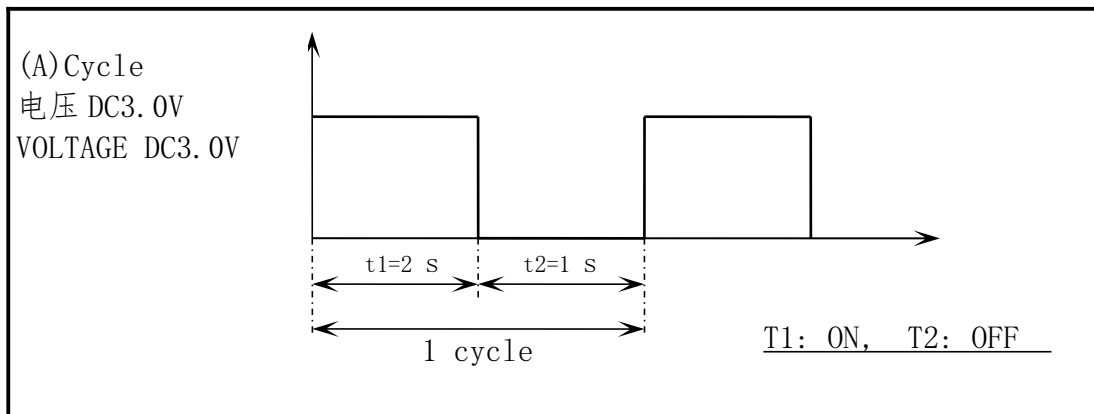
**8-1-1 常温寿命试验/Room Temperature Life Test**

1.按A周期运行96小时/To maintain (A)cycle for 96hrs in the process of temperature shock.

**8-2-1 高温寿命试验/High temperature Exposure Life test**

1.按A周期运行48小时/To maintain(A)cycle under high temperature for 48hrs.

**8-3-1 低温寿命试验/Low temperature Exposure Life test**

1.按A周期运行48小时/To maintain(A)cycle under high temperature for 48hrs.

极限可靠性模拟验证:

### 测试参数/Test Parameters

马达测试/Motors tested: 10  
 测试时间/Test time: 96 hours  
 循环周期/Cycle period: 3 seconds  
 占空比/Duty cycle: 90%  
 测试电压/Test voltage: 3.0 V  
 温度/Temperature: 25°C ± 3  
 湿度/Humidity: 50%RH ± 5

从威布尔分布中得出关键可靠性数字的公式/Formulas to derive the key reliability figures from a Weibull distribution:

$$MTTF = \eta \cdot t (1 + 1/\beta)$$

$$FIT = 10^9 / MTTF$$

### 试验结果/Test Result

在威布尔图中给出了长寿试验的结果。

The results for the longevity test are presented in a Weibull plot.

从拟合分布可以得到平均失效时间的估计值。

From the fitting distribution it is possible to obtain an estimate of the Mean Time to Failure.

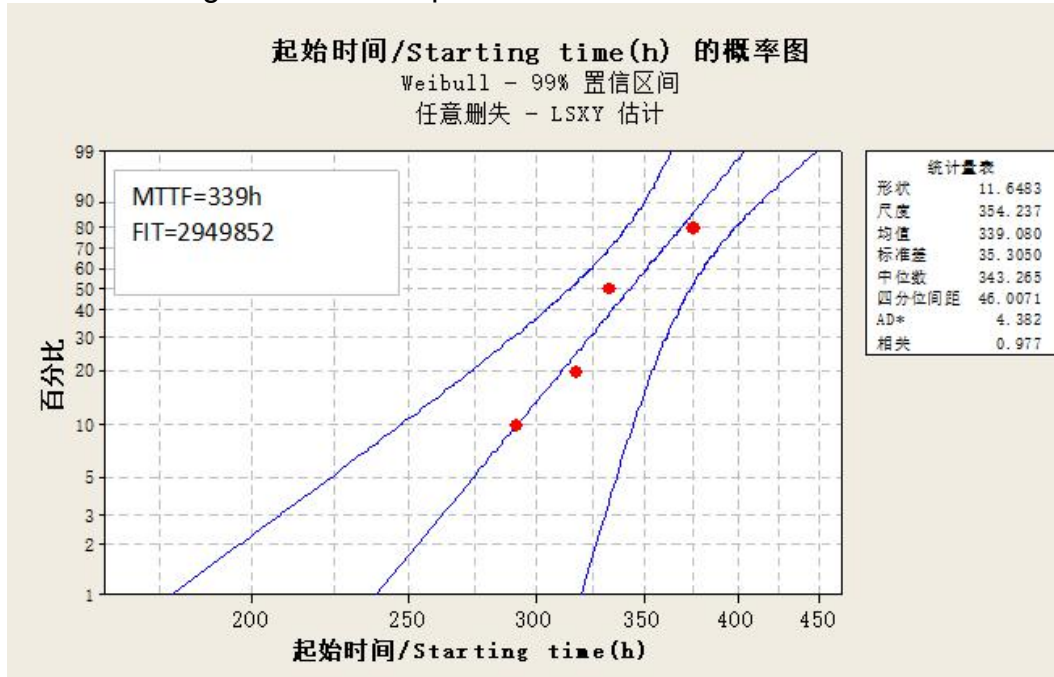

### ▶ 判定标准/Judgment standard

① 试验后，测试数据必须符合以下规格：

After test, measured data must be satisfied as following specifications;

- 启动电压: DC2.3V MAX.
- Starting voltage: DC2.3V MAX.
- 额定转速: 变化率在初始值的+30%~-20%以内。
- Rated speed: changing rate must be within +30%~-20% of initial value.
- 额定电流: 变化率在初始值的+20%~-30%以内。
- Rated current: changing rate must be within +20%~-30% of initial value.

## 9. 环保要求/Environment Protections

本产品所有零部件符合欧盟RoHS2.0/无卤/REACH指令要求，具体环境有害物质管控限制如下：

This product conforms to the EU ROHS2.0, halogen-free and REACH certification, Specific content as follows:

铅及其化合物最大允许含量为1000ppm/Lead and Lead compounds $\leq$ 1000ppm

镉及其化合物最大允许含量为1000ppm/Cadmium and cadmium compounds $\leq$

1000ppm

汞及其化合物最大允许含量为1000ppm/Mercury and Mercury compounds $\leq$ 1000ppm

六价铬化物最大允许含量为1000ppm/Hexavalent chromium compounds $\leq$ 1000ppm

多溴联苯(PBB)最大允许含量为1000ppm/Polybrominated biphenylethers $\leq$ 1000ppm

多溴联苯醚(PBDE)最大允许含量为1000ppm/Polybrominated diphenylethers $\leq$

1000ppm

邻苯二甲酸二正丁酯(DBP)最大允许含量为1000ppm /DBP $\leq$ 1000ppm

邻苯二甲酸正丁基苄酯(BBP)最大允许含量为1000ppm/BBP $\leq$ 1000ppm

邻苯二甲酸(2-己基)己酯(DEHP)最大允许含量为1000ppm/DEHP $\leq$ 1000ppm

六溴环十二烷(HBCDD)最大允许含量为1000ppm/HBCDD $\leq$ 1000ppm

溴Br最大允许含量为900ppm/Br $\leq$ 900ppm

氯Cl最大允许含量为900ppm/Cl $\leq$ 900ppm

溴加氯之和最大允许含量为1500ppm/Br+Cl $\leq$ 1500ppm

REACH 指令按最新法规内容管控执行/The instructions are subject to the latest regulations

包装材料环保管控要求：Pb, Cd, Hg, Cr+6 : 4 种物质总和 < 100ppm (其中, Cd<50ppm)/

Environmental control requirements for packaging materials: Pb+Cd+Hg+Cr6 <

100ppm (其中, Cd<50ppm)

## 10. 注意事项/Caution

- (1) 该马达是微型精密产品，在运输过程中不要承受超过0.5 kgf的力，否则会引起外形或性能的变化。  
As this motor is small and precise, do not press it over 0.5kgf force or while transportation, otherwise it will cause the transformation of performance or external appearance.
- (2) 请注意马达不要接触到液体性物质（比如：水，酒精等）  
Please keep the motor away from liquid substance (such as water, alcohol, etc.)
- (3) 不要在高温下长时间放置，否则有可能导致电机的性能下降。  
Do not expose the motor to high temperature for a long time, it may cause a decline in performance.
- (4) 马达不要在以下环境中使用：
  - 高温和高湿的场所
  - 腐蚀性气体如H<sub>2</sub>S、SO<sub>2</sub>、NO<sub>2</sub>等Avoid using the motor in the following environment.
  - High temperature and high humidity area.
  - Corrosive gas such as H<sub>2</sub>S、SO<sub>2</sub>、NO<sub>2</sub> etc.
- (5) 请不要在靠近磁铁或带有磁场的仪器旁边使用或存放马达。  
Please do not operate or store the motor adjacent to magnet or apparatus which has a magnetic field.
- (6) 请注意机壳的表面存在漏磁通量。  
Please be careful that there exists a leaking magnetic flux on the surface of bracket.
- (7) 电刷和换向器的相互作用，有可能产生轻微的电噪音。  
Due to interaction between brush and commutator, there is a possibility to occur electrical noise slightly.
- (8) 因测试设备有误差，允许有±5%偏差。  
Due to the measurement equipment error, there is a ± 5 % difference tolerance.

- (9) 接电端子扭曲、折弯次数不可多于 2 次。  
Current terminals should not be twisted or bent more than twice.
- (10) 被焊锡的端子局部受压不可多于 2 次。  
The portion when lead wire and terminal are soldered should not be under stressed more than twice.
- (11) 在马达通电时，不宜长时间锁住不转。  
Do not subject the motor under locked condition for long hours.
- (12) 不可向马达一侧强行挤压接电端子。  
Do not exert pressure by pushing the current terminals towards the direction of the internal motor.
- (13) 马达通过 ROHS 认证  
This motor pass the system of ROHS certification.

(14)

出厂检验报告附上 35 只马达特性数据和 CPK 值,其中包括:

负载转速: rpm

负载电流: mA

堵转电流 (启动电流): mA

启动电压: 不考虑 CPK 值

Attached to OQC report are 35 motors' characteristic data and CPK value, including:

Loaded rotation: rpm.

Loaded current: mA

Lock current (Starting current): mA

Starting voltage: without the consideration of CPK value .

**11.外形图/Outside View**

技术要求/Technique requests:

- 1.电机轴向间隙0.3mm Max/  
Axial play of shaft is 0.3mm max  
when counterweight rotating;
- 2.A 面、B 面共面,  $A_1$ 、B 面的高度差为  $-0.03 \sim +0.1$ mm/  
Coplanarity Plane A and B are coplanar, altitude tolerance  
of plane of A with B is  $-0.03 \sim +0.1$ .

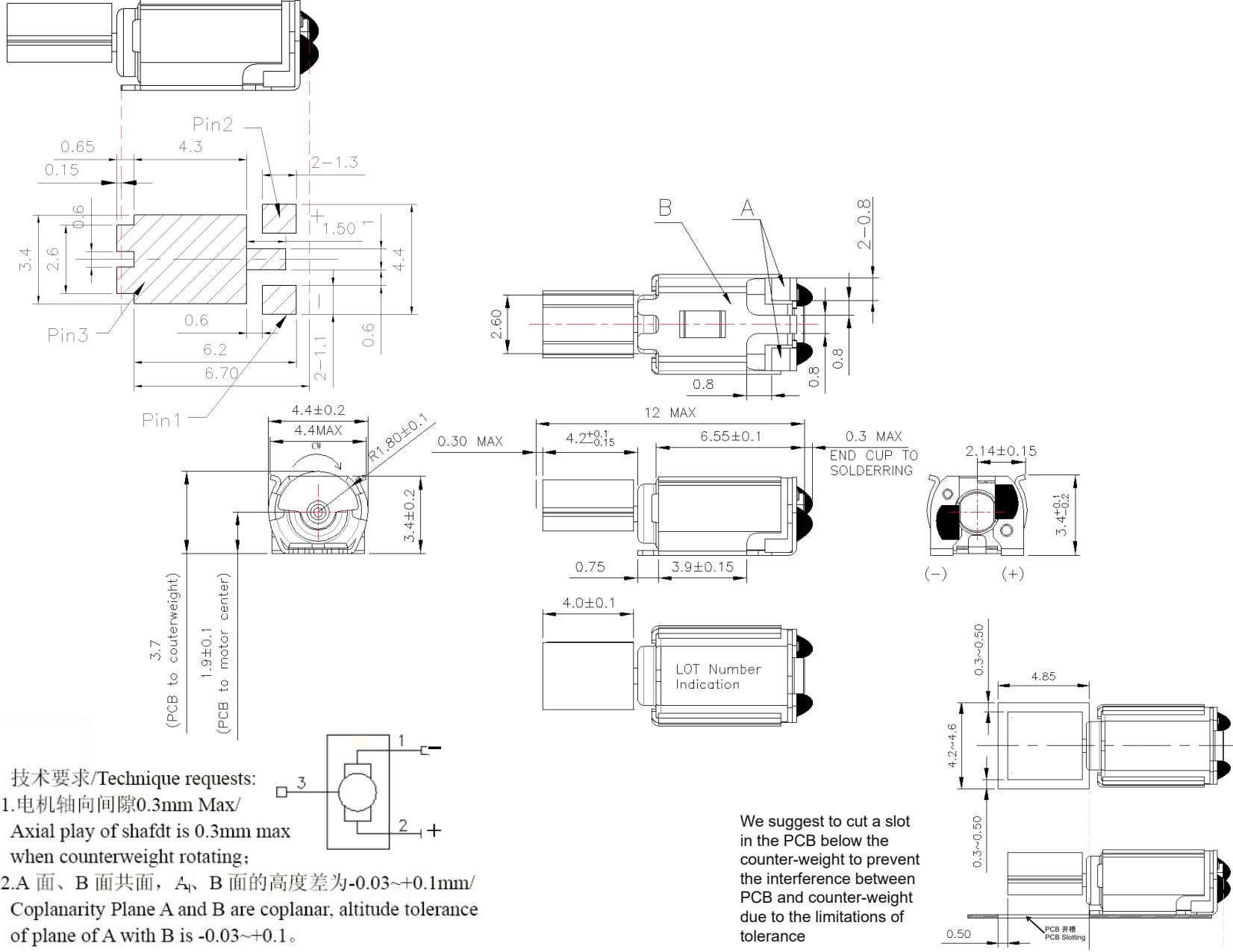
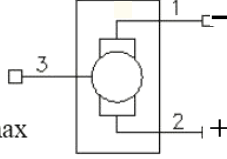

We suggest to cut a slot in the PCB below the counter-weight to prevent the interference between PCB and counter-weight due to the limitations of tolerance

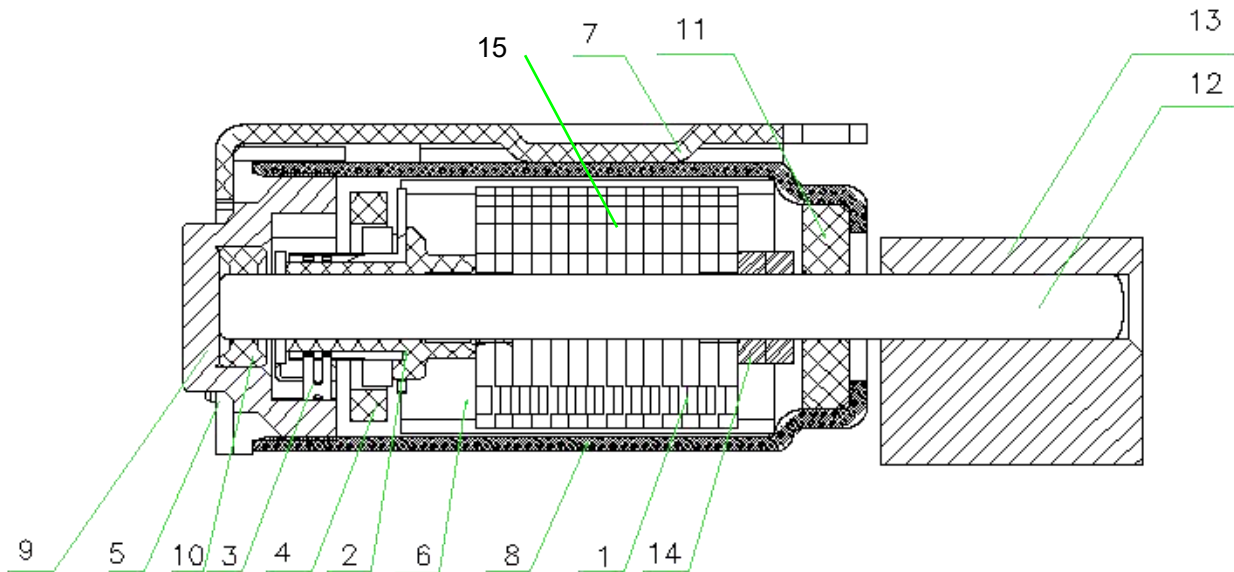

**12. 结构图及物料清单/Structure Drawing & BOM**

| NO. | 部件名称/Part name          | 材料名称/Material name           |
|-----|-------------------------|------------------------------|
| 1   | 涂装铁芯/Iron core          | 20HTH1500                    |
| 2   | 整流子/Commutator slice    | SP-2/MX215/LCP               |
| 3   | 电刷/Brush                | SP-1/MX96                    |
| 4   | 变阻/Varistor             | 钛酸锶/SrTiO3                   |
| 5   | 焊锡端子/Terminal           | 黄磷铜/Yellow phosphorus copper |
| 6   | 磁钢/Magnet               | 钕铁硼/NdFeB                    |
| 7   | 支架/Bracket              | SUS301                       |
| 8   | 机壳/Case                 | SPCC                         |
| 9   | 基板/Brush board          | PA46                         |
| 10  | 外壳轴承/Bearing            | 铜铁基/Cu                       |
| 11  | 基板轴承/bearing            | 铜铁基/Cu                       |
| 12  | 钢轴/Shaft                | DSR7B                        |
| 13  | 分铜/Counterweight        | 钨合金/Tungsten alloy           |
| 14  | 套管/Casing               | PA46                         |
| 15  | 漆包线/Enamel Covered wire | 铜线/Cu                        |

13. 包装要求/Packaging Requirement

13.1 最小包装/Smallest Packing

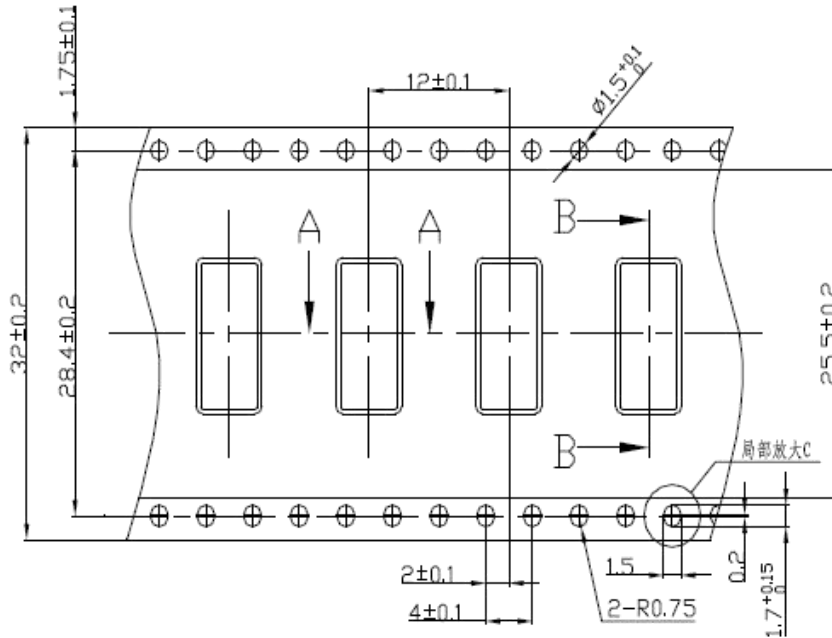

13.2 卷轴包装/1 reel packing dimension

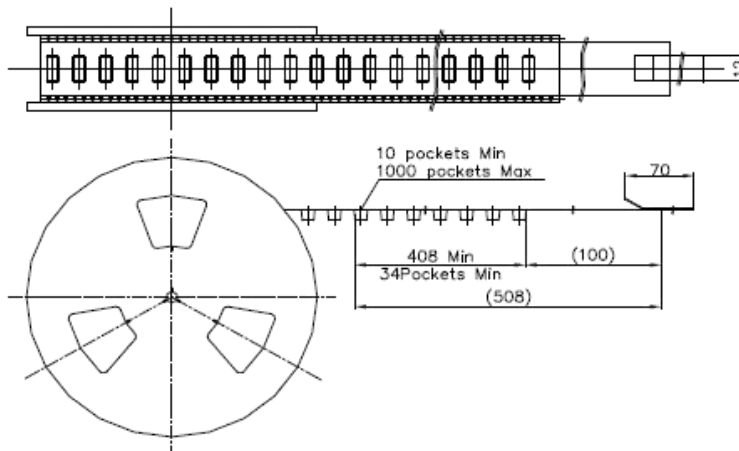

13.3 最终包装/Final Packing Condition

双层波纹纸/Double wall corrugated carboard (internal dimension)

1000pcs/1 reel x 5reel = 5000pcs

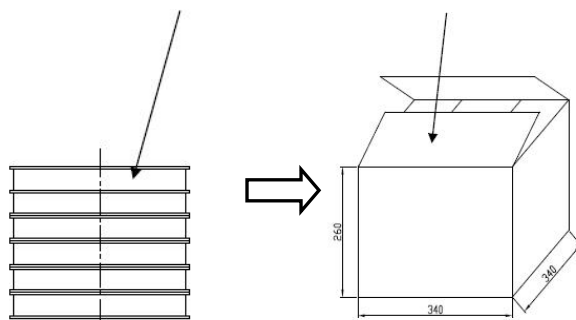

5 个卷盘装入外箱, 数量共 5000 只;  
Put 5 reels into outer box, total 5000 Pcs.

外箱尺寸: (长 340mm 宽: 340mm 高: 260mm)

Outer-box dimension:  
(L: 340mm W: 340mm H: 260mm)

14. 生产过程中回流老化后检查 /The inspection after reflowing is implemented in product process.

### Reflow Specification

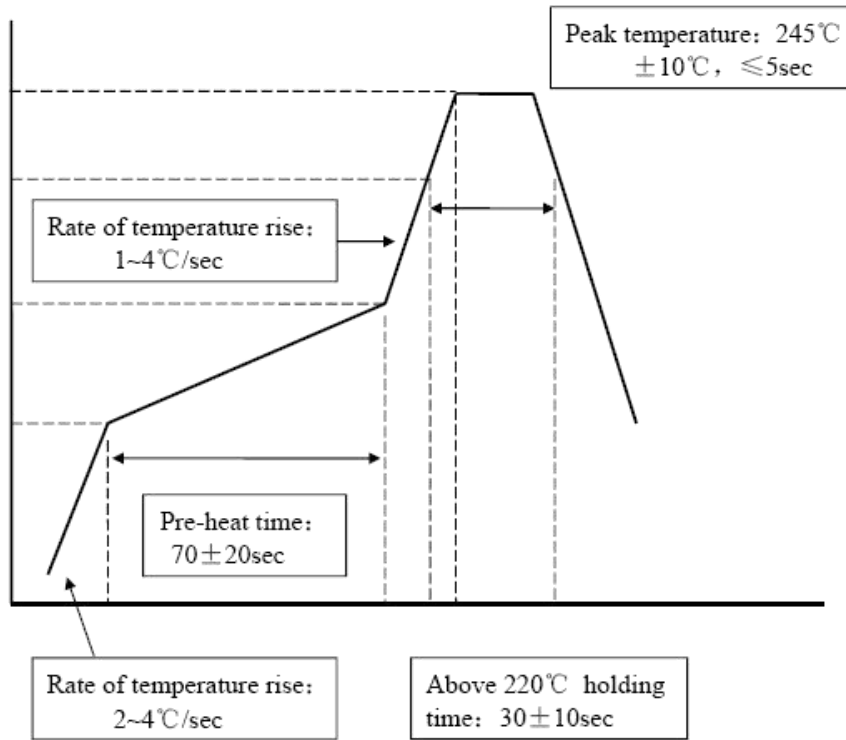

Peak temperature maximum 245°C/5sec.