



# 产品规格书

## PRODUCT SPECIFICATION

客户名称Buyer Name	
客户料号Buyer Part No.	
客户承认签章 Buyers Approval & Signatures	

文件编号Spec No.		版本	A/2
品名描述 Product Description	无刷直流振动马达 BLDC Vibration Motor		
型号Part No.	VW0934AB001G		
送样日期Date			
设计Designed by	审核Checked by	批准Approved by	
2023.04.05	2023.04.05	2023.04.05	

www.vybronic.com

sales@vybronic.com

NO	ITEM	Page
1	Revision History	3
2	Scope	4
3	Contents	4
4	Standard Test Condition	4
5	Judgment Environmental Condition	5
6	Test Tolerance	5
7	Electrical Characteristics	5
8	Mechanical Characteristics	6
9	Reliability Test	7~8
10	Caution	9
11	Specification Change	10
12	Drawing	11



## 2. Scope

This specification is applies to VW0934AB001G vibration motors to be used for mobile telephone or IT devices.

## 3. Contents

No.	Item	Specification
3-1	Operating Voltage Range	DC 2.7V ~ 3.3V
3-2	Storage Temperature Range	(-)40 ~ (+)85°C
3-3	Operating Temperature Range	(-)30 ~ (+)70°C However, there is 45% decrease of rated load speed of the section 7-3 at -30°C compared to +25°C.
3-4	Operating Position	All Direction

## 4. Standard Test Condition

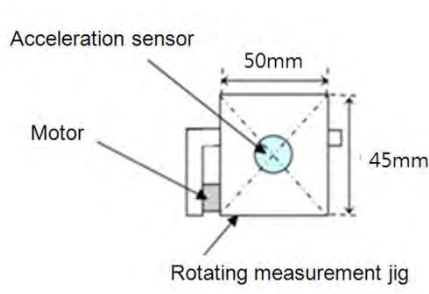
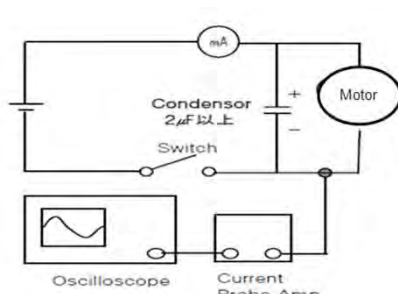
No.	Item	Specification
4-1	Temperature	20 ± 15°C
4-2	Humidity	65% ± 20% RH
4-3	Measurement Voltage	DC3.0V
4-4	<div style="display: flex; justify-content: space-around; align-items: flex-start;"> <div style="text-align: center;">  <p>Acceleration sensor</p> <p>Motor</p> <p>Rotating measurement jig</p> <p>50mm</p> <p>45mm</p> </div> <div style="text-align: center;">  <p>mA</p> <p>Condensor 2μF以上</p> <p>Switch</p> <p>Motor</p> <p>Oscilloscope</p> <p>Current Probe Amp.</p> </div> </div> <div style="display: flex; justify-content: space-around; margin-top: 10px;"> <div style="border: 1px solid black; background-color: #e0f0e0; padding: 5px; width: 45%;"> <p style="text-align: center; margin: 0;"><b>Standard Measurement State</b></p> </div> <div style="border: 1px solid black; background-color: #e0f0e0; padding: 5px; width: 45%;"> <p style="text-align: center; margin: 0;"><b>Inspection Circuit Diagram</b></p> </div> </div> <ul style="list-style-type: none"> <li>- Jig : 50 x 46 x 45mm [Material is POM]</li> <li>- Weight: 150g</li> <li>- The vibrator is Clamped firmly (0.5~1Kg pressure) on a test fixture</li> </ul>	

**5. Judgment Environmental Condition**

NO	Item	Condition
5-1	Temperature	20 ± 15%℃
5-2	Humidity	65% ± 20%RH

**6. Test Tolerance**

Test set-ups and equipment shall be capable of maintaining following condition, unless otherwise specified.

NO	Item	Condition
6-1	Room Temperature & Humidity	20 ± 15%℃ / 65 ± 20%RH
6-2	Test Chamber Temperature	Limits ± 3℃
6-3	Voltage	Limits ± 0.15V

**7. Electrical Characteristics**

No	Item	Test Condition	Condition
7-1	Rated Voltage		DC 3.0V
7-2	Rotating Direction	CW [Lead Wire Red(+), Black(-)] CW [Lead Wire Red to (+), Black to (-)]	CW
7-3	Rated Load Speed	It is based on the standard measurement condition of the section 4.	11,500 ± 2,500 rpm
7-4	Rated Load Current		80 mA max
7-5	Starting Current		175 mA max
7-6	Starting Voltage	Motor 4-1, 4-2, 4-4 On/Off . Motor On/Off test based on the standard measurement condition of the section 4-1, 4-2, and 4-4.	DC 2.5 V max
7-7	Insulation Voltage	。 Measured between terminal and case with DC 100V Megger .	10 MΩ min

**8. Mechanical Characteristics**

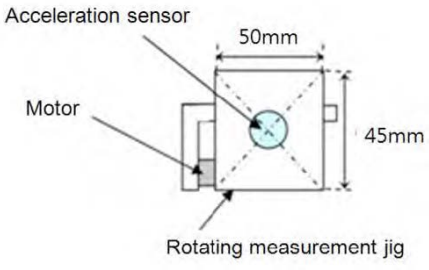
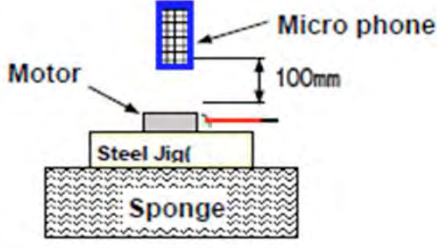
NO	Item	Specification	Condition
8-1	Vibration Force	<ul style="list-style-type: none"> <li>- Vibration Force: 1.4Grms (AVG.)</li> <li>- 50 x 46 x 45mm [Material is POM]</li> <li>- Weight : 150g</li> <li>- The vibrator is Clamped firmly (0.5~1Kg pressure) on a test fixture,</li> </ul> 	It is referred to the rated load speed of the section 7-3
8-2	Mechanical Noise	<ul style="list-style-type: none"> <li>- Motor shall be fixed on Jig by adhesive tape</li> <li>- Jig Material</li> </ul> 	50dB 50dB MAX 24dB
8-3	Weight		about 1.0g

**9. Reliability Test**

NO	Item	Test Condition			Specification
9-1	Life Test				-
			Room Temp. & Humi. L/T	High Temp. & Humi. L/T	
		Voltage	DC 3.0V	DC 3.0V	
		Temperature	20±15℃	40℃	
		Humidity	65±20% RH	90% RH	
9-2			Life cycles	1,000,000 cycles	
		Duty Cycle	0.5 sec ON / 0.5 sec OFF	0.5 sec ON / 0.5 sec OFF Motor shall be fixed on Jig by adhesive tape. (Refer to the section 4-4)	
9-3	Composite Test	Conduct the continuous running for 10 hours as following Then storage at 60℃ 90% for 500hours			(Rated Load Speed: Initial value±20%, or within rated load speed)
9-4	Low Temperature Storage Performance	Exposed to -40℃ for 500 hours and then room temperature for 4 hours.			(Rated Load Current: Initial value ±30%)
9-5	High Temperature Storage Performance	-Exposed to +85℃, 60%RH for 500 hours and then room temperature for 4 hours.			
9-6	High Temperature and Humidity Storage Performance	- Exposed to +60℃, 90%RH for 500 hours and then room temperature for 4 hours.			

**9. Reliability Test**

NO	Item	Test Condition	Specification
9-7	Thermal Shock Test	Total 200cycles at -40°C and +85°C for 30min each (1cycle=1 H)  -Temperature Change Time < 5min -Motor shall be measured after exposure  at room temperature for 4 hours.	-(Rated Load Speed: Initial value ±20%, or within rated load speed)  (Rated Load Current: Initial value ±30%)
9-8	Drop Test	Dummy set (about 130g) motor shall be dropped onto concrete plate. 3times each side of 6 directions from a height of 150 cm, total 18 times.	
9-9	Vibration Test	Standard-packed motor is subjected to sine wave 10Hz~55Hz. X, Y, Z directions for 2 hours each., total 6 hours.	

**Table 1. Evaluation items after reliability test**

No.	Items	Specification
1-1	Rated current	Rated Load Current: Initial value ±30%
1-2	Rated speed	Rated Load Speed: Initial value ±30%, or within rated load speed
1-3	Acoustic noise	50dB(A) max.
1-4	Others	No deformation, crack, separation of parts.

**※ A dummy jig for free-drop**

Mass : 100gr ± 10%

Size : 110 X 65 X 16 mm

Material : POM

Thickness of the cushion tape : 1.0mm

(Compressive ratio : 50%)

The upper case is faced to the cushion tape



**10. Caution**

NO	Item	Specification
10-1	Operating Range	-When using on the operating condition different from a standard, a problem can be generated to the performance and the life of a product.
10-2	Storage	- Avoid from placing motor for long term of six months under environmental condition of high temperature or extreme humidity, or motor may be deteriorated.
10-3	Motor Handling	<p>To handle the motor, hold the case softly.</p> <p>.</p> <p>.</p> <p>Do not bring a magnetized object or attracted object by the magnet of motor, or such object may deteriorate a performance of motor.</p> <p>Input short to the motor due to mis-operating, Drive IC of the motor inside can be damaged. To avoid this problem, please add capacitor of 2uF or more between the power lines in parallel with the motor.</p> <p>Supplying voltage more than DC4.5V can make IC out of function.</p>
10-4	Motor Usage	- Motor must be installed in device within 6 months of our ship date. For best reliability, it is recommended that the motor be exercised by powering it up for 3 seconds when the device is powered on.

## 11. Specification Change

Even when there is any change to this specification, change application report which has the information of details

- of the change, lot of product, and etc shall be presented to customer before that change being carried out.

- And mutual discussion may be necessary before the change being carried out.

Revision history shall be recorded on to the specification sheet when the change record and approval may be required.

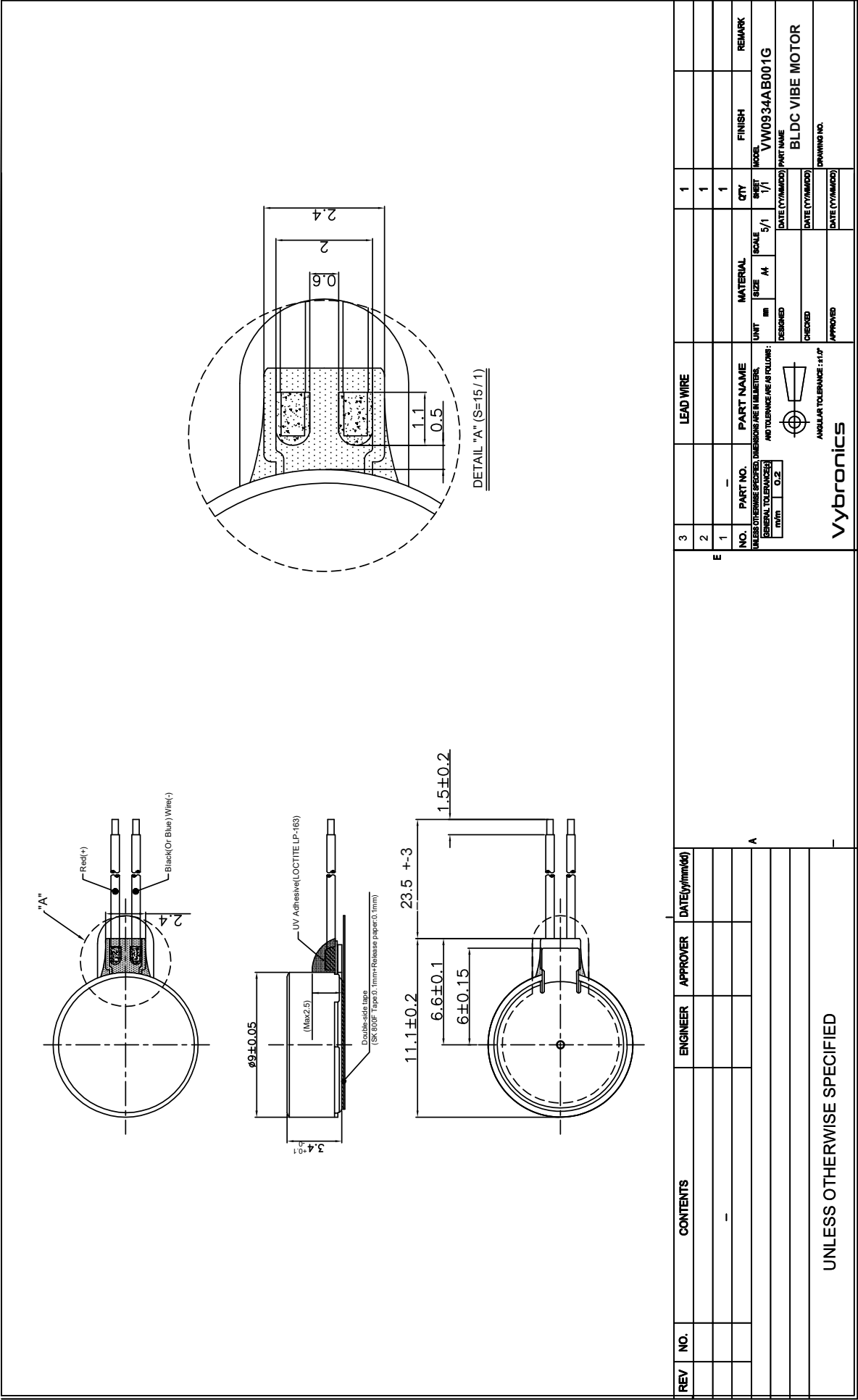

REV	NO.	CONTENTS	ENGINEER	APPROVER	DATE (y/m/d)
	3				
	2				
	1				

NO.	PART NO.	PART NAME	LEAD WIRE	1	1	
QTY				1	1	
MATERIAL						
UNIT	mm	mm				
SCALE	5/1					
DATE (Y/M/D)						
DESIGNED						
CHECKED						
APPROVED						

MODELS	VW0934AB001G	REMARK	
PART NAME	BLDC VIBE MOTOR		
DATE (Y/M/D)			
DRAWING NO.			

UNLESS OTHERWISE SPECIFIED