



产品规格书

PRODUCT SPECIFICATION

客户名称 Buyer Name	
客户料号 Buyer Part No.	
客户承认签章 Buyers Approval & Signatures	

文件编号 Spec No.		版本	A/1
品名描述 Product Description	圆柱直流马达 Cylindrical DC motor		
型号 Part No.	VQ6DL2AQ140001		
送样日期 Date			
设计 Designed by	审核 Checked by	批准 Approved by	
2022.11.09	2022.11.09	2022.11.09	

www.vybronic.com

sales@vybronic.com

规格书内容/Contents

1、适用范围/ General Scope	3/10
2、使用条件/ Operating Conditions	3/10
3、测定条件/ Measuring Conditions	3/10
4、机械要求/ Mechanical Specifications	3/10
5、性能特征/Performance and characteristics	4/10
6、可靠性/Reliability	5/10
7、要求/Requirements	6/10
8、使用时注意事项/ Attentions	6/10
9、外形图/Outline Drawing	7/10
10、电机性能曲线/Motor Performance Curve	8/10
11、包装/Packaging	9/10
12、修改记录 / Revision History	10/10

1. 适用范围/General

本规格书适用于空心杯永磁直流电机 VQ6DL2AQ140001。

This specification applies to Coreless Permanent Magnetic DC motors Model: VQ6DL2AQ140001.

2. 使用条件/Operating Condition

项目/Item	规格/Specification	条件·备注/Condition Remark
2-1 额定电压 Rated voltage	1.3V DC	
2-2 旋转方向 Direction of Rotation	C.W. (Clockwise)	
2-3 马达位置 Motor Posture	全方位 All positions	
2-4 使用电压范围 Operating Voltage	0.9~1.6V DC	
2-5 使用环境 Operating Environment	-20~60℃ 10~90% RH	
2-6 保存环境 Storage Environment	-40~80℃, 5~95% RH	无水气凝结 No condensation of moisture

3. 测定条件/Measuring Condition

项目/Item	规格/Specification	条件·备注/Condition Remark
3-1 温度 Temperature	20±2℃	
3-2 湿度 Humidity	65±5% RH	
3-3 位置 Motor posture	轴向水平 Motor shaft horizontal	将马达固定在试验台上 Lock the motor in a test fixture

标准测试条件为温度 20℃，湿度 65%。如无疑异，也可在温度 5~35℃、湿度 45~85%的条件下测试。马达测试时，放置方向为轴向水平。/The measurement at 20℃ & 65%RH is standard. If the judgment is not questionable, recognize measurement at 5℃ to 35℃ & relative humidity 45% to 85%. Direction of motor is shaft horizontal.

4. 机械要求/Mechanical specification

项目/Item	规格/Specification	条件·备注/Condition Remark
4-1 结构 Configuration	见外形图 As specification outline Drawing	Outline Drawing No: VQ6DL2AQ140001
4-2 外观 Appearance	不含有机机械损坏及不充分的浸蚀等。 There shall be no mechanical Damage And inadequate corrosion and so on	目测（容许范围根据样品外形） Visual examination (allowable extent is based on boundary sample)
4-3 轴向间隙 Shaft play	0.05mm~0.3mm	

5.性能特征/Performance and characteristics

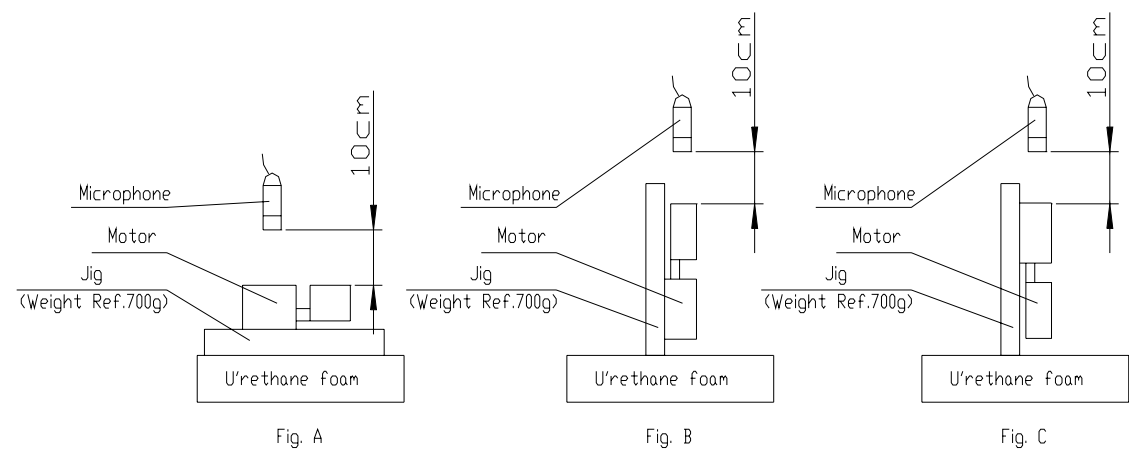
项目/Item		规格/Specification	条件·备注/Condition Remark
5-1	空载转速 Non load speed	14,000±2000 rpm	在额定电压下。 At rated voltage.
5-2	空载电流 Non load current	33 mA Max	
5-3	堵转电流 Stall current	155 mA Max	在额定电压下 At rated voltage.
5-4	起动电压 Starting Voltage	0.8V DC Max	在额定负载（无振子）下电枢的任意位置。 At rated load (non vibration weight) any position of rotor.
5-5	端子阻抗 Terminal resistance	10.5Ω (±20%)	在 20℃ 下 At 20℃
5-5	绝缘电阻 Insulation resistance	1MΩ Min	在 100V 直流下 At DC 100V between
5-6	机械噪音 Mechanical noise	50dB(A)Max	<p>在额定电压下。 At rated voltage. 背景噪音：不大于 28db.A 计权 Back ground noise 28db(A) Max. 测试仪器：B&k Measuring instruments: B&k 夹具重量：700g Weight of jig: 700g</p> 

6. 可靠性/Reliability

项目/Item		规格/Specification	判定标准/Judgment
6-1	低温放置 Low temp exposure	温度 /Temperature : $-40\pm 2^{\circ}\text{C}$ 时间 /Time : 96h	在常温常湿下放置 2h 后, 马达应符合项 7 的要求。 After 2 hours exposure in ordinary temperature and humidity, Motors shall be approved as specified in item 7.
	高温放置 High temp. Exposure	温度 /Temperature : $80\pm 2^{\circ}\text{C}$ 时间 /Time : 96h	
	湿度放置 Humidity exposure	温度 /Temperature : $40\pm 2^{\circ}\text{C}$ 湿度 /Humidity : 90~95%RH 放置时间 /Exposure time : 96h 无水气凝结/No condensation of moisture	
6-4	振动 Vibration	全振幅 /Displacement : 1.5mm (p-p) 频率 /Frequency: 10 ~ 55Hz 加速度 /Acceleration: 22m/s^2 周期 /Period: 20min 完成 10~55~10Hz /20 Minutes log sweep 10~55~10Hz 方向 /Direction: x, y, z 时间 /Time: 每个方向 2h /Each 2 hours	测试结果应符合项 7 的要求。 After the test motors shall be approved as specified in item 7.
		6-5	自然跌落 Free fall

7. 要求/Requirements

项目/Item	判定基准 / Requirements
1)空载转速/Rated speed	不大于初始值 $\pm 30\%$ /Initial data $\pm 30\%$ max
2)空载电流/Rated current	不大于初始值 $\pm 30\%$ /Initial data $\pm 30\%$ max
3)起动电压/Starting voltage	1.0V DC Max

8. 使用时注意事项/Matters to be paid attention to when using motor

8-1 电机在运输过程中应小心轻放, 避免严重碰撞敲击引起的电机机身和性能受损。(Please lay the motors carefully in transportation to avoid any serious damage to the motor body or its electric function because of collision.)

8-2 请按照规格书中规定的第 2 条(使用条件)来使用和存储电机, 否则会影响电机性能。(Please use and storage motors according to N0.2 item (Operating Conditions) in specification, or else motor characteristics would be affected.)

8-3 请在 6 个月内使用。在使用和打开马达外包装时请避免水气凝结。(Make arrangement to limit the storage period to 6 months or less. Condensation of atmosphere must be avoided in motor usage or opening the packaging of the motor.)

8-4 马达应适当的操作、储存和运转环境中均不可存在腐蚀性气体。例如: H_2S 、 SO_2 、 NO_2 、 CL_2 等。另外存储环境中不可有诸如硅、氰、甲醛水和苯酚等能放射出腐蚀性气体的物质, 在电机的机械构造或装置中, 如果存在腐蚀性气体, 那么这会引起马达不运转。(For proper operation. storage and operating environment must not contain corrosive gases. For example H_2S . SO_2 . NO_2 . CL_2 . etc. In addition storage environment must not have materials that emit corrosive gases especially from silicon. cyanic. formalin and phenol group. In the mechanism or the set. existence of corrosive gases may cause no rotation in motor.)

8-5 请通电后不要长时间堵住机轴, 并且马达转动时不要触碰转子。(Please don't stall the shaft for a long time after powering, and not to touch the weight when motor is rotating.)

8-6 马达轴向间隙处不应有杂物(如颗粒、纤维物、头发、胶带、胶水等)(There should be no sundries (such as grain, fibre, hair, small tape, glue etc.) in the shaft end play.)

9. 外形图/Outline Drawing

- 技术要求/Technical requirement**
1. 额定电压/Rated voltage: 1.3V
 2. 空载电流/Non load current: 33mA Max
 3. 空载转速/Non load speed: 14,000 ± 2000rpm
 4. 堵转电流/Stall current: 155mA Max
 5. 端子阻抗/Terminal resistance: 10.5Ω(±20%)
 6. 起机电压/Starting voltage: 0.8V Max
 7. 导线规格/Lead wire spec: AWG30 UL1571
 8. 未注线性公差为/Unmarked tolerance: ± 0.1mm
 9. A向压力/Pressure along A direction : 20N Max
 10. 端盖颜色: 黑色/Theenot covers colour: Black

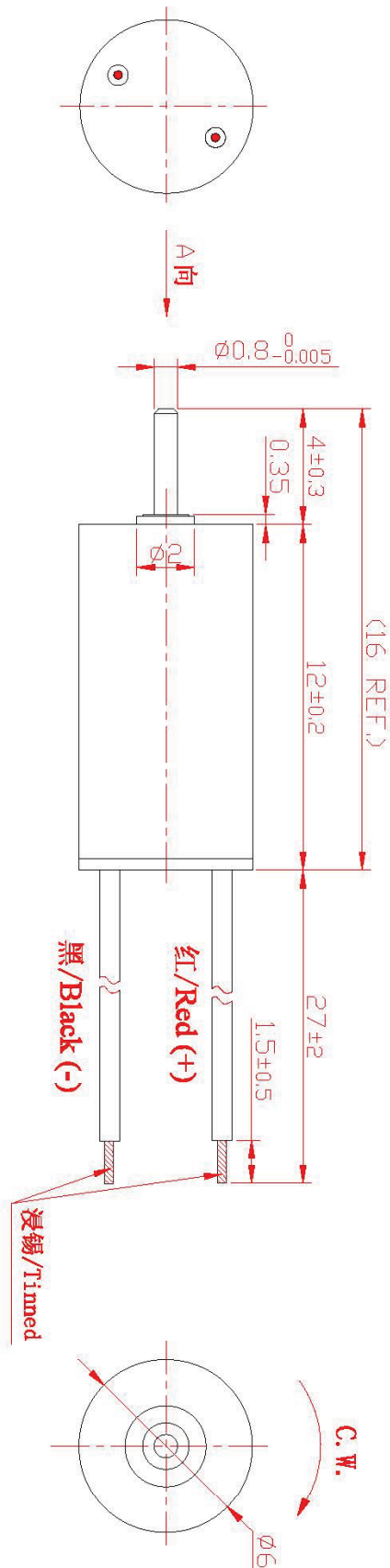

MOTOR PERFORMANCE CURVE

电机性能曲线

客户名称 Customer _____
电机型号 Motor Model VQ6DL2AQ140001

额定电压 Rated Voltage 1.3 V/DC
额定负荷 Rated Load 模拟负载
测试日期 Test Date 2022.11.09

Parameters Table 性能参数表		F/L 空载	Eff (max) 最大效率点	P (max) 最大功率点	Stall 堵转点
转矩 Torque :	g.cm	0	0.18	0.27	0.55
转速 Speed :	RPM	14430	9769	7215	0
电流 Current :	mA	29.6	62.0	79.8	130.0
输出 Output :	W	0	0.02	0.02	0
效率 Efficiency :	%	0	21.9%	19.5%	0

特征参数 Parameters		
转矩常数 Torque Constant :	5.433	g cm/A
转速常数 Speed Constant:	14373	RPM/V
速度/转矩常数 Motor Regulation	26453.4	Rpm/g.cm

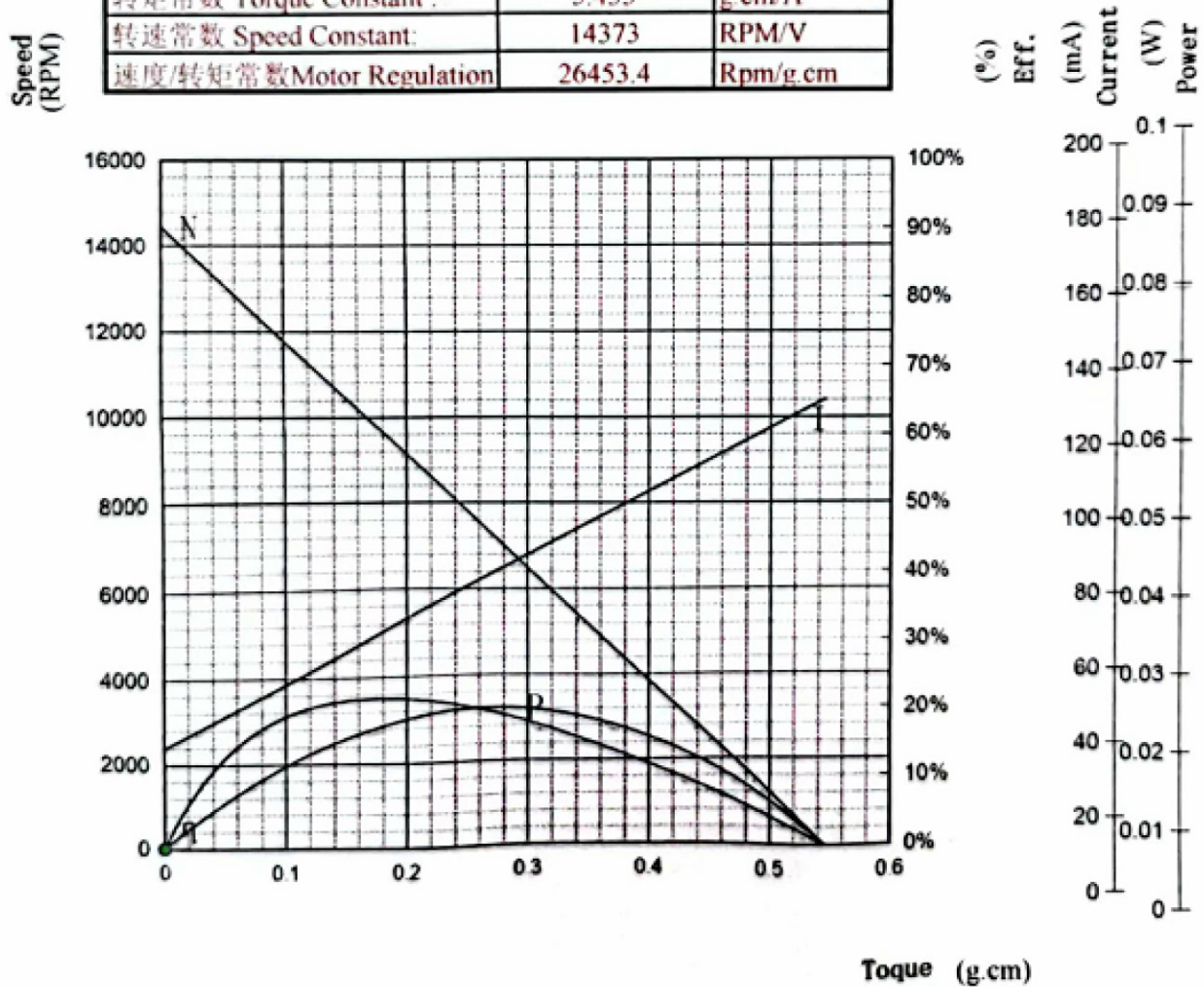

NOTES: Performance (In an ambient temperature of 25 -30°C)
Motor tested rapidly to prevent significant temperature rise.

备注：电机测试环境温度：常温25 -30°C
电机测试迅速，以防止温度显著上升。

11. 包装/Packaging

圆柱马达包装 Packaging drawing of cylindrical motor

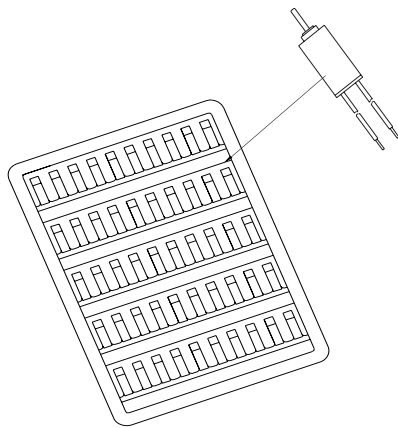

100 PCS (1 tray) × 10

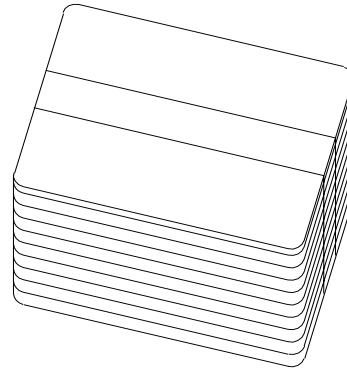

1000PCS (1 bundle) × 6

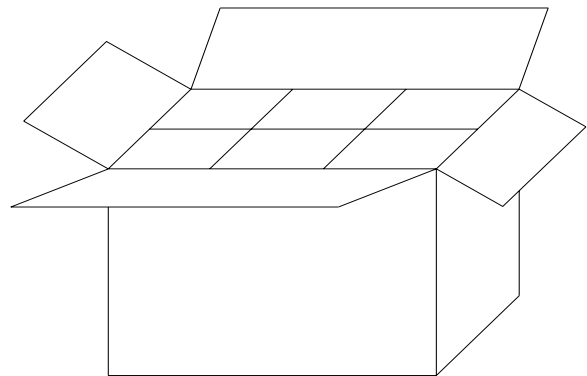
包装试验要求
1. 标准

- (1) 整箱重量小于等于9kg的, 跌落高度设定为75cm.
- (2) 整箱重量大于9kg但小于等于23kg的, 跌落高度设定为60cm.

2. 试验方法:

跌落要求为六面三棱一角.

- (1) 六面: 先从最大两面跌, 然后是中间大小的两面, 最后跌最小的两面, 一共六次.
- (2) 三棱: 指任选三条同一角的棱, 跌落秩序: 最长棱, 中间长度, 最短的, 一共三次.
- (3) 一角: 指上一步三条棱所组成的角, 跌落一次.

3. 判定基准

经过跌落试验后, 产品外观、性能无不良.

Package Test Requirement:
1. Criteria

- (1) The weight of the whole carton less than 9kg, the dropping height is 75cm.
- (2) The weight of the whole carton more than 9kg and less than 23kg, the dropping height is 60cm.

2. Test Methods:

Dropping requirement is 6 faces, 3 arris, 1 angle.

- (1) 6 faces: First dropping with two biggest faces, then dropping with another two middle faces, at last dropping with two smallest faces, once per face, total 6 faces.
- (2) 3 arris: Choose any 3 arris which make up of the same the angle, the dropping sequence is the longest arris, middle arris, shortest arris. Total 3 times.
- (3) 1 angle: Point to the angle which is made up with the 3 arris in the above step. Dropping for 1 time.

3. Judgement Criterion

After drop test, no evidence of damage on the appearance and performance.

Remarks:

- 1000PCS/CTN: 34cm × 24cm × 27.5cm
 2000PCS/CTN: 47cm × 34cm × 27.5cm
 3000PCS/CTN: 51cm × 47cm × 27.5cm

OPP TAPE

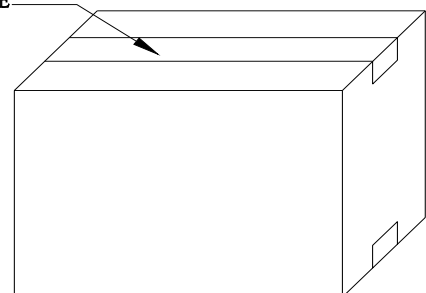

12. 更改记录/ Revision History

修改号 Rev. No.	日期 Rev. Date	页码 Page No.	修改项目 Revised Item	更改原因 Reason
A/0	2009.05.12	/	初期规格/Preliminary spec	
A/1	2022.11.09	/	- Changed company name from JINLONG MACHINERY to VYBRONICS, - Changed part # from Q6DL2AQ140001 to VQ6DL2AQ140001 - Renew motor performance curve	Rebranding