



产品规格书

PRODUCT SPECIFICATION

客户名称Buyer Name	
客户料号Buyer Part No.	
客户承认签章 Buyers Approval & Signatures	

文件编号Spec No.		版本	A/2
品名描述 Product Description	扁平振动马达 Coin type vibration motor		
型号Part No.	VC0824K001L		
送样日期Date			
设计Designed by	审核Checked by	批准Approved by	
陳满	陈满	陈满	
2020.07.01	2020.07.01	2020.07.01	

www.vybronic.com

sales@vybronic.com

- 内容/CONTENTS -

01. 规格书内容/CONTENTS	1/13
02. 更改记录/Records of Revision	2/13
1. 适用范围/Scope of application	3/13
2. 使用条件/Standard operating condition	3/13
3. 测试条件/Testing condition	4/13
4. 电气特性/Electrical characteristics	4/13
5. 机械特性/Mechanical characteristics	5/13
6. 环境试验/Environmental test	6/13~7/13
7. 寿命试验/Life test	8/13
8. 注意事项/Caution	9/13
9. 附/Attached	10/13
9-1 马达特性图/characteristic graph of motor	
9-2 标准测量方式/state of standard measurement	
10. 外形图/Outside view	11/13
11. 结构图及物料清单/Structure drawing & BOM	12/13
12. 包装/Packaging	13/13

更改记录/ Records of Revision

修改号 Rev. No.	日期 Rev. Date	页码 Page No.	修改项目 Revised Item	更改原因 Reason
A/0	2019.02.12	/	产品颁布/Release for Production	
A/1	2019.02.13	/	① 马达外径由 $\Phi 8 \pm 0.1$ 改为 $\Phi 8.05 \pm 0.05$; ② 增加马达字码规则。	
A/2	2020.07.01	/	changed company name from JINLONG MACHINERY to VYBRONICS, changed part # from C0824K001L to VC0824K001L	Rebranding

1. 适用范围/Scope of application

This specification sheet is stipulated for vibration motor, which is for mobile phone.

2. 使用条件/Standard operating condition

NO.	项目/Item	规格/Specifications
2-1	额定电压 Rated voltage	DC3.0V
2-2	使用电压范围 Operating voltage range	DC 2.5~3.5V
2-3	旋转方向 Rotating direction	CW / CCW
2-4	使用温度范围 Operating temperature range	-30℃~+70℃
2-5	保存环境范围 Storage temperature range	-40℃~+80℃

3. 测试条件/Testing condition

NO.	项目/Item	规格/Specifications
3-1	温度 Temperature	25℃ ± 3
3-2	湿度 Humidity	45% ~85%RH
3-3	电源电压 Power supply, voltage source	直流电源或电池 3.0V DC power supply or battery 3.0V
3-4	马达安放状态 Posture of motor	标准测量方式 State of standard measurement

4. 电气特性/Electrical characteristic

NO.	项目/Item	单位 /Unit	规格/SPEC.	条件/Condition
4-1	额定转速 Rated speed	rpm	10000Min	额定电压: DC 3.0V Rated voltage: DC 3.0V
4-2	额定电流 Rated current	mA	85Max	额定电压: DC 3.0V Rated voltage: DC 3.0V
4-3	启动电压 Starting voltage	V	2.3Max	DC2.3V电压下, 开/关为1个循环, 共3个循环 On/off-1cycle, total 3cycles under DC2.3V
4-4	端子阻抗 Terminal resistance	Ω	单相 1phase: 30 ± 20% 双相 2phase: 60 ± 20%	正极和负极之间 Between positive and negative
4-5	启动电流 Starting current	mA	120Max	启动电压: DC 2.3Max Starting voltage: DC 2.3Max
4-6	绝缘电阻 Insulation resistance	MΩ	10Min	测量机壳和引线之间。 测试电压直流100V。 Measuring between case and lead wire. Test voltage DC 100V

5. 机械特性/Mechanical characteristics

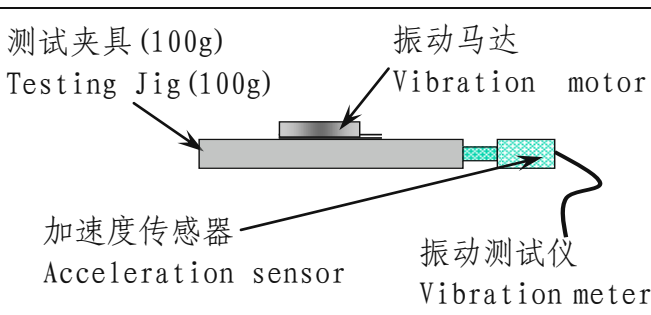
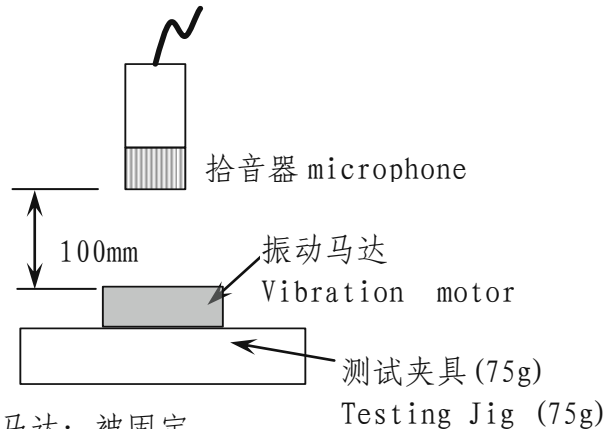
NO	项目/Item	单位/Unit	规格/SPEC.	条件/Condition
5-1	振动量 Vibration Strength	G	0.6 MIN	<p>测试夹具 (100g) Testing Jig (100g)</p>  <p>振动马达 Vibration motor</p> <p>加速度传感器 Acceleration sensor</p> <p>振动测试仪 Vibration meter</p> <p>马达: 被固定。 Motor: be fixed. 额定电压: DC 3.0V Rated voltage: DC 3.0V .</p>
5-2	机械噪音 Mechanical Noise	dB	50 MAX	 <p>拾音器 microphone</p> <p>100mm</p> <p>振动马达 Vibration motor</p> <p>测试夹具 (75g) Testing Jig (75g)</p> <p>马达: 被固定。 Motor: be fixed 额定电压: DC 3.0V Rated voltage: DC 3.0 V 背景噪音: 25dB MAX. Back ground noise: 25dB MAX. 拾音器沿轴向正对电机平面 Microphone faces the plane of motor along the shaft</p>
5-3	底盖偏转强度 Bracket Deflection Strength	gf	1000 MIN	<p>通过推拉计进行破坏测试 Demolition test by push-pull gauge.</p>
5-4	重量 Weight	g	0.55 ± 0.1	<p>用天平测量 Use scale</p>

6. 环境试验/Environmental test

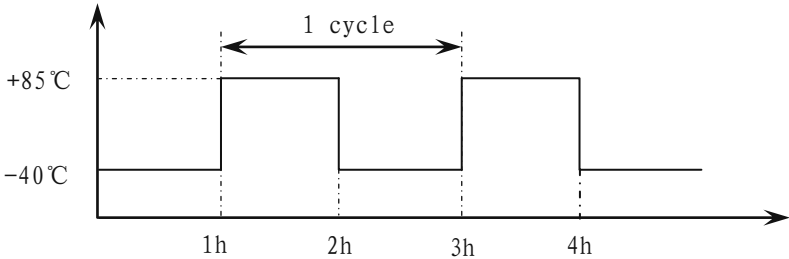
NO	项目/Item	条件/Condition
6-1	低温贮存试验 Low temperature Storage test	在-40℃的环境下放置96小时，然后在常温常湿下恢复2小时后测试。 Exposed at -40℃ for 96hours, then return to normal temperature and humidity for 2 hours before test.
6-2	高温贮存试验 High temperature Storage test	在+80℃的环境下放置96小时，然后在常温常湿下恢复2小时后测试。 Exposed at +80℃ for 96hours, then return to normal temperature and humidity for 2 hours before test.
6-3	高湿贮存试验 High humidity Storage test	在+40℃, 90%RH的环境下放置96小时，然后在常温常湿下恢复2h后测试。 Exposed at +40℃ 90%RH for 96hours, then return to normal temperature and humidity for 2 hours before test.
6-4	温冲试验 Thermal shock test	马达按照以下试验条件放置 15 个周期，然后在常温常湿下放置 2 小时后测试。 Confirmed to operating of motor during 15 cycles as following test condition, then return to normal temperature and humidity for 2 hours before test. 试验条件: Test condition:  高低温转换时间: ≤5分钟 Transfer time between high temperature and low temperature: ≤5min
6-5	跌落 Drop test	将马达固定在100g的塑料夹具上，从1.5米的高度跌落到水泥地面上，六个面的每个面都跌落2次。 The motor that is attached to a 100g jig (plastic housing) and drop it onto the concrete floor from 1.5m height. Drop twice in each of the six planes.

6-6	振动试验 Vibration test	将马达固定在100g的塑料夹具上，按以下要求进行试验： 1) 振频范围: 10-55Hz 2) 全振幅1.5mm 3) 振频变化10-55-10 约10分钟 4) 振动方向: 三个垂直方向 5) 持续时间: 每个方向10分钟（共30分钟） The motor that is attached to a 100g jig (plastic housing) and test according following condition: 1) Vibration frequency range: 10~55Hz 2) Total amplitude: 1.5mm 3) Sweep ratio: 10~55~10Hz approximate 10min 4) Direction of vibration: Three perpendicular directions 5) Duration: 10min(30min in total)
-----	------------------------	---

► 判定标准/Judgment standard

④ 试验后，测试数据必须符合以下规格：

After test, measured data must be satisfied as following specifications;

- 启动电压: DC2.3V MAX.
- Starting voltage: DC2.3V MAX.
- 额定转速: 变化率在初始值的-30%~+50%以内。
- Rated speed: changing rate must be within -30%~+50% of initial value.
- 额定电流: 变化率在初始值的-30%~+50%以内。
- Rated current: changing rate must be within -30%~+50% of initial value.
- 端子阻抗: 变化率在初始值的±15%以内。
- Terminal resistance: changing rate must be within ±15% of initial value.

⑤ 外形结构无异常。

There should be no abnormalities in appearance and structure.

7. 寿命试验/Life test
▶ 试验条件/Test condition:

1 秒转, 1 秒停为 1 个周期, 共 10 万次。

(DC3.0V, 常温常湿)

1 SEC ON, 1SEC OFF 1CYCLE , 100,000 CYCLES.

(DC3.0V, at normal temperature and humidity)

▶ 判定条件/Judgment standard:

试验后, 测试数据必须符合以下规格:

After test, measured data must be satisfied as following specifications;

- 启动电压: DC2.3V MAX.
- Starting voltage: DC2.3V MAX.
- 额定转速: 变化率在初始值的-30%~+50%以内。
- Rated speed: changing rate must be within -30%~+50% of initial value.
- 额定电流: 变化率在初始值的-30%~+50%以内。
- Rated current: changing rate must be within -30%~+50%of initial value.

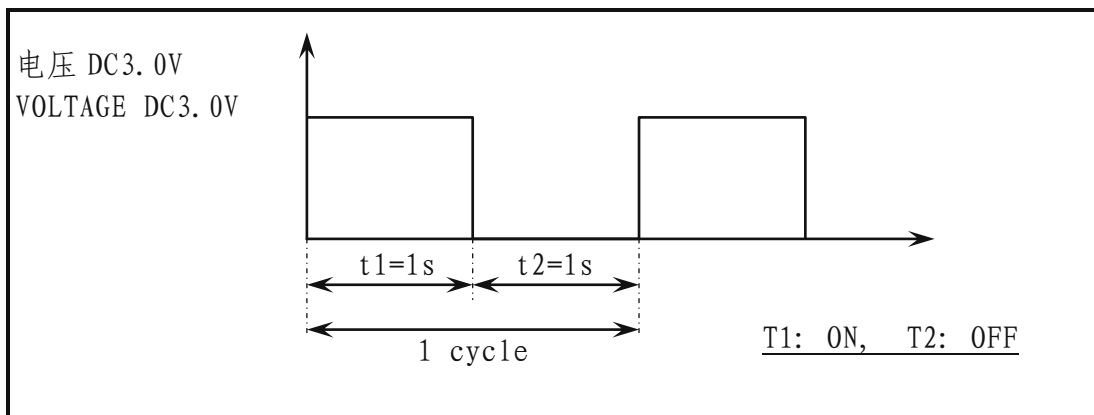

8. 注意事项/CAUTION FOR USE

- (1) 该马达是微型精密产品，在运输过程中不要承受超过0.5 kgf的力，否则会引起外形或性能的变化。

As this motor is small and precise, do not press it over 0.5kgf force or while transportation, it can cause the transformation of performance or external appearance.

- (2) 请注意马达不要接触到液体性物质（比如：水，酒精等）
please be careful, not to be contacted fluid substances
(such as: water, alcohol etc.)

- (3) 不要在高温下长时间放置，否则有可能导致电机的性能下降。

Do not expose the motor to high temperature for a long periods of time, it may cause a decline in performance.

- (4) 马达不要在以下环境中使用：

- 高温和高湿的场所
- 腐蚀性气体如H₂S、SO₂、NO₂等

Avoid using the motor in the following environment.

- High temperature and high humidity area.
- Corrosive gas such as H₂S、SO₂、NO₂ etc.

- (5) 请不要在靠近磁铁或带有磁场的仪器旁边使用或存放马达。

Please do not operate or store the motor adjacent to magnet or apparatus That has a magnetic field.

- (6) 请注意底盖的表面存在漏磁通量。

Please be careful that there exists a leaking magnetic flux on the surface of bracket.

- (7) 电刷和换向器的相互作用，有可能产生轻微的电噪音。

Due to interaction between brush and commutator, there is a possibility to occur electrical noise slightly.

- (8) 因测试设备有误差，允许有±5%偏差。

Beacause there is error of the measurement equipment ,permit the standard of the rotational frepency to ±5%

- (9) 马达通过ROHS认证

This motor pass the system of ROHS certification

9. 附/Attached

9-1 马达特性图/characteristic graph of motor

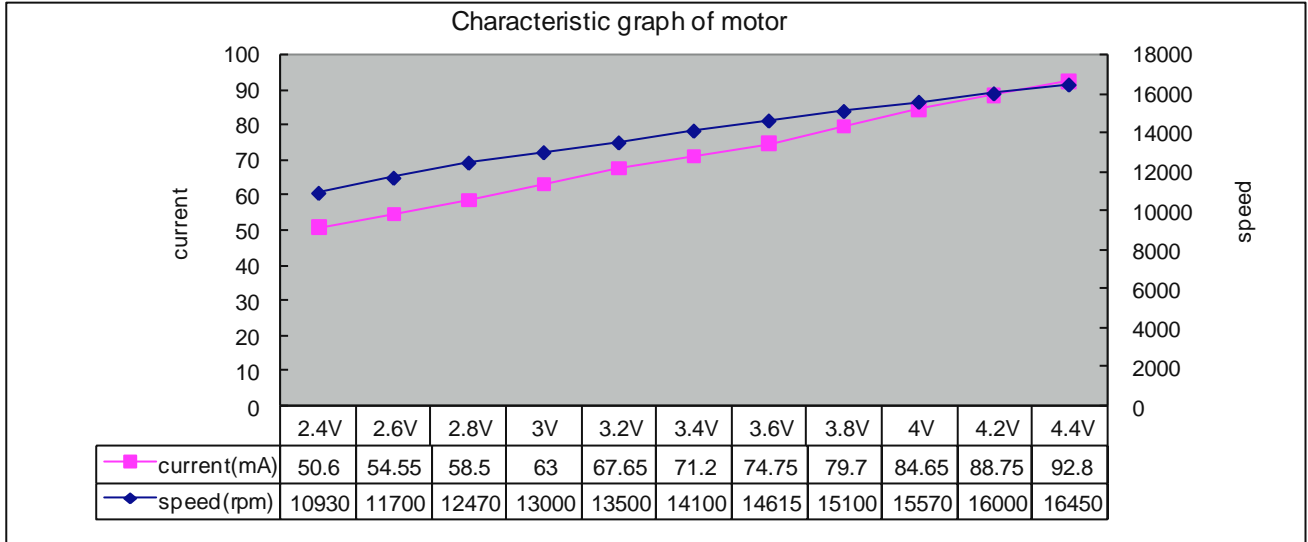

9-2 标准测量方式/state of standard measurement

测试项目: 启动电压, 额定电压下的电流, 额定电压下的转速, 绝缘电阻。

Measure item: starting voltage, current at rated voltage, speed at rated voltage, insulation resistance.

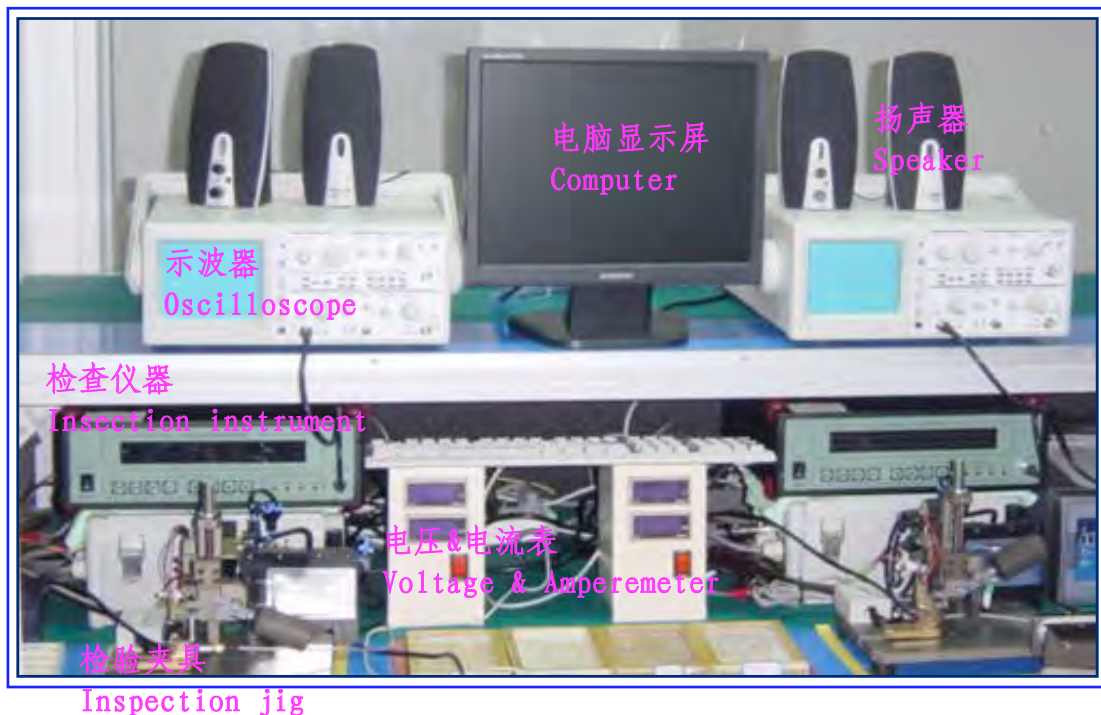

10. 外形图/Outside view

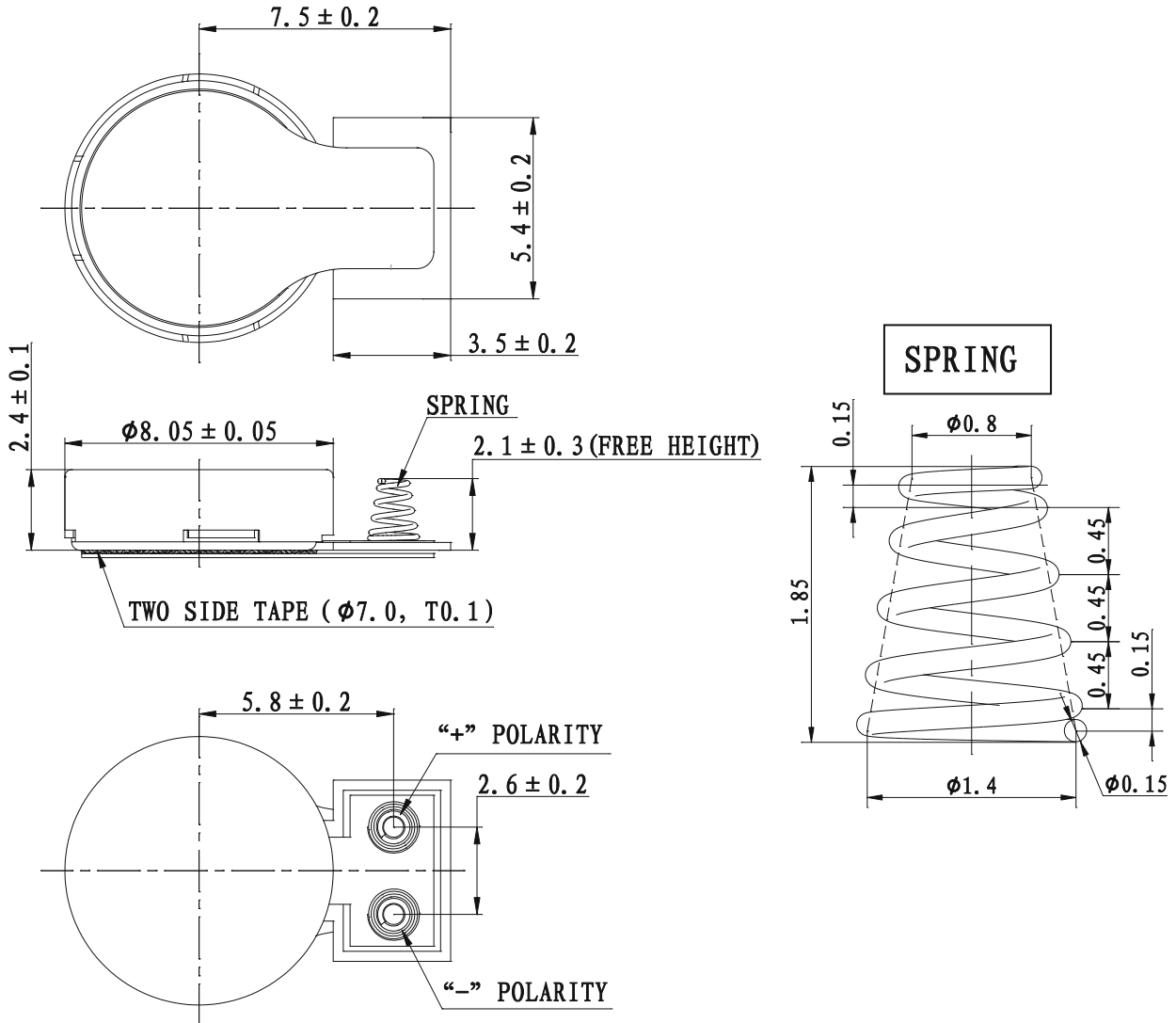

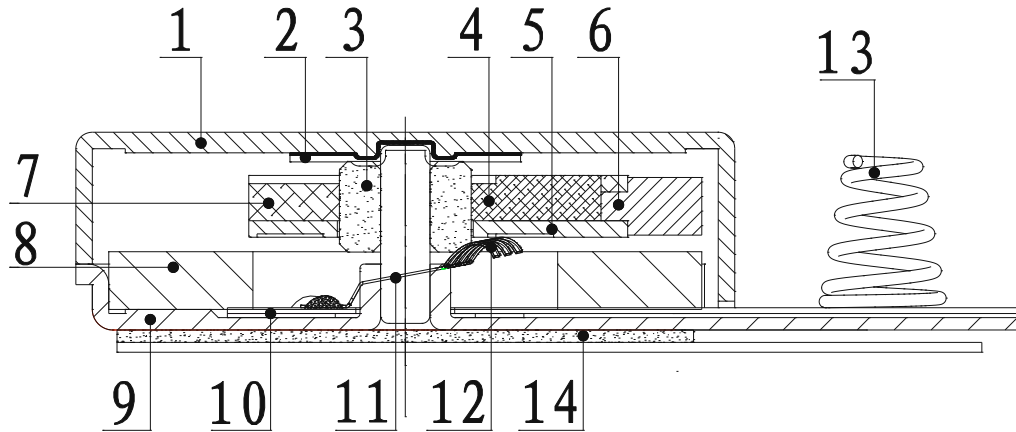
11. 结构图及物料清单/Structure drawing & BOM

NO.	物料名称/Part name	材料/Material	规格/specification
1	上机壳 Upper case	SPC-E	T =0.23mm
2	滑片 Slide	PE+ACRYLIC	T =0.1mm
3	轴承 Bearing	FCS	
4	线圈 Coil	Copper+PU	
5	硬基板 HPCB	EPOXY	T =0.2mm
6	振子 Weight	Tungsten alloy	0.07g Min
7	塑料 Resin	PBT	G30
8	磁钢 Magnet	NdFeB	N42H
9	下机壳 Lower case	SPC-E	T =0.25mm
10	软基板 FPCB	PI+AD+Copper+Glue	T =0.07mm
11	钢轴 Shaft	DSR7B	φ 0.6
12	电刷 Brush	MX215	T =0.03mm
13	弹簧 Spring	SWP-B	
14	双面胶 Two side tape	Non-woven fabrics+ Acrylic adhesive	T=0.1mm

12. 包装/Packaging



吸塑盒尺寸 (长: 250mm 宽: 210mm 高: 11mm)

Tray dimension (L: 250mm W: 210mm H: 11mm)

每个吸塑盒放 100 只

100 Pcs per tray

内箱尺寸 (260mm 宽: 215mm 高: 80mm)

Inner-box dimension (L: 260mm W: 215mm
H: 80mm)

每 11 个吸塑盒捆在一起, 数量为 1000 只,
装入内箱

Put into inner-box 11 tray together
with tape 1000 Pcs per 11 tray .

4 个内箱装入外箱, 数量共 4000 只;

Put 4 inner-box into outer-box, total
4000 Pcs.

外箱尺寸: (450mm 宽: 280mm 高: 180mm)

Outer-box dimension:

(L: 450mm W: 280mm H: 180mm)