



产品规格书

PRODUCT SPECIFICATION

客户名称Buyer Name	
客户料号Buyer Part No.	
客户承认签章 Buyers Approval & Signatures	

文件编号Spec No.		版本	A/1
品名描述 Product Description	扁平振动马达 Coin type vibration motor		
型号Part No.	VC0820B006F		
送样日期Date			
设计Designed by	审核Checked by	批准Approved by	
陳满	陈满	陈满	
2020.07.01	2020.07.01	2020.07.01	

www.vybronic.com

sales@vybronic.com

规格书内容/ Contents

1. 适用范围/General Scope of Application	1/8
2. 使用条件/Operating Conditions	1/8
3. 测定条件/Conditions of Measurement	1/8
4. 电气性能/Electrical Characteristics	1/8
5. 机械性能/Mechanical Characteristics	2/8
6. 耐久性能/Reliability Test	2/8
7. 要求/Requirements after Reliability Tests	4/8
8. 使用注意事项/Cautions for Use	5/8
9. 包装/Packaging Description	6/8
10. 外形图/Outline Drawings	7/8
11. 更改记录/Records of Revisions	8/8

1. 适用范围/General Scope of Application

本说明书适用于扁平式永磁直流电机 VC0820B006F 系列。

This specification applies to coin type permanent-magnetic motors DC model VC0820B006F.

2. 使用条件/Operating Conditions

项目/Item	规格/Specifications
2-1 额定电压 Rated voltage	3.0V DC
2-2 使用电压范围 Operating voltage	2.7~3.3V DC
2-3 旋转方向 Rotation	CW (clockwise) or CCW (counter clockwise)
2-4 使用环境 Operating environment	-20~60℃,常湿/Ordinary Humidity:65±20%RH
2-5 保存环境 Storage environment	-30~70℃,常湿/Ordinary Humidity:65±20%RH

3. 测定条件/Conditions of Measurement

项目/Item	规格/Specification
3-1 温度 Temperature	25±3℃
3-2 湿度 Humidity	65±20% RH
3-3 电源电压 Power supply	稳压直流电源 3.0V。 Constant Power supply 3.0V DC.

4. 电气性能/Electrical Characteristics

项目/Item	规格/Specification	条件/Condition
4-1 额定转速 Rated speed	10,000rpm Min	额定电压下。 At rated voltage.
4-2 额定电流 Rated current	85mA Max	
4-3 起动电流 Starting current	120mA Max	在最小起动电压下起动。 Motor is rotating at minimum starting voltage.
4-4 起动电压 Starting voltage	2.5V DC Max	
4-5 绝缘电阻 Insulation resistance	10MΩ Min	在 100V 直流下，导线和机壳间。 At DC 100V between lead wire and case.
4-6 端子阻抗 Terminal resistance	30 Ω ±20%(单相single posture) 60 Ω ±20%(双相compose posture)	在 25℃下。 At 25℃

5. 机械性能/Mechanical Characteristics

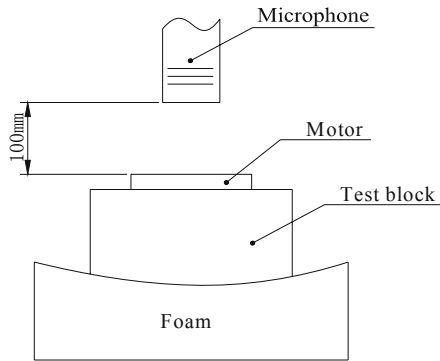
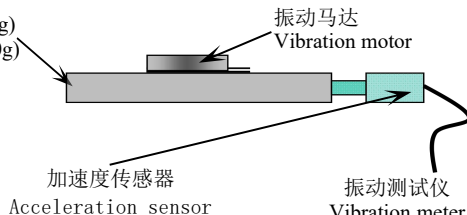
项目/Item	规格/Specification	
5-1	底盖偏转强度 Bracket Deflection strength	9.8N 以上 9.8N or more.
5-2	机械噪音 Mechanical noise	小于 50 分贝. A 计权 50dB (A) Max. 在额定电压下。At rated voltage. 背景噪音: 不大于 28dB. A 计权. Back ground noise 28dB (A) Max.
		
5-3	振动量 Vibrations 0.3 Grms Min 0.45 Gp Min	测试夹具(100g) Testing Jig(100g) 

6. 耐久性能/ Reliability Tests

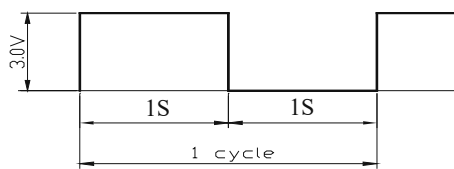
项目/Item	规格/Specification	判定标准/Judgment
6-1 寿命 Lifetime	额定电压/ Rated voltage: 3.0V DC 试验模式/ Test mode: 1s On, 1s Off, as one cycle. 循环次数/ Test cycle: 100,000 cycles 	试验后, 马达应符合项 7-1 的要求。After the test, motors shall be approved as specified in item 7-1.
6-2 低温放置 Low temperature exposure	温度/Temperature: -30°C 时间/Time: 96h	常温常湿下放置 4h 后, 马达应符合项 7-2 的要求。After 4 hours exposure in ordinary temperature and humidity, motors shall be approved as specified in item 7-2.
6-3 高温放置 High temperature Exposure	温度/Temperature: $+70^{\circ}\text{C}$ 时间/Time: 96h	常温常湿下放置 4h 后, 马达应符合项 7-2 的要求。After 4 hours exposure in ordinary temperature and humidity, motors shall be approved as specified in item 7-2.

7. 判定基准/ Judgments after Reliability Tests

项目/Item		判定基准 / Requirements
7-1	表 A Table A	1)额定转速/Rated speed: 不低于初始值-30%; 不高于初始值+50%/ No lower than -30% of initial data; No more than +50% of initial data. 2)额定电流/Rated current: 不低于初始值-30%; 不高于初始值+50% No lower than -30% of initial data; No more than +50% of initial data. 3)端阻/Terminal resistance: 不大于初始值±15% No more than +15% of initial data; No less than -15% of initial data. 4)起动电压/Starting voltage: 不大于 2.5V 直流电压 2.5V DC Max 5)绝缘电阻/Insulation resistance: 大于 10MΩ/ 10MΩ Min
7-2	表 B Table B	1)额定转速/Rated speed: 不大于初始值±20% No more than +20% of initial data; No less than -20% of initial data. 2)额定电流/Rated current: 不大于初始值±20% No more than +20% of initial data; No less than -20% of initial data. 3)起动电压/Starting voltage: 不大于 2.5V 直流电压 2.5V DC Max 4)端阻/Terminal resistance: 不大于初始值±15% No more than +15% of initial data; No less than -15% of initial data.

8. 使用时注意事项/ Cautions for Use

8-1 必须按照规格书标准使用, 否则性能和寿命都将受到相当地减少, 必须注意电压的使用范围。
Unless it is used in accordance with the specifications, the performance and life may be considerably reduced. Due attention should be paid to voltage and range for use.

8-2 建议马达在六个月内使用, 不要在以下环境中使用及保存:

1. 高温和高湿的场所;
2. 腐蚀性气体,如: H₂S、SO₂、NO₂、Cl₂;
3. 生锈场所。

Advice uses this motor within 6 months as avoiding as possible.

Avoid use or save the motor in the following environment.

1. High temperature and high humidity area
2. Corrosive gas such as H₂S, SO₂, NO₂, Cl₂.
3. Dusty area.

8-3 注意处理马达的工作环境, 避免含铁质等物体被马达吸住, 否则马达将会产生噪声, 性能会降低, 从而减少产品可靠性。

Due attention must be paid to the handling and working environments because such objects as iron powder if attracted by the motor magnet, will cause noise, characteristic deterioration thus reducing the reliability.

8-4 应确信本产品不会与相关标准、法律、政令相背。

Please confirm enough no problems of standards and laws and ordinances on your cellular phone.

8-5 拿马达时, 要轻拿轻放。

To handle the motor, hold the motor case softly.

8-6 钢板面或边缘有少许锈斑是允许的。

Rust of plate (steel) and similar edge should be OK.

8-7 我司遵循持续发展的策略, 在不预先通知的情况下, 有对产品(部品)进行修改和改进的权利, 当然这些都不会影响马达的特性及使用功能。

Our company follows the sustainable developing strategy, and have the right to make changes and improvements to our product without giving notice in advance. Of course, these changes and improvements will not affect the characteristics and function of the motor.

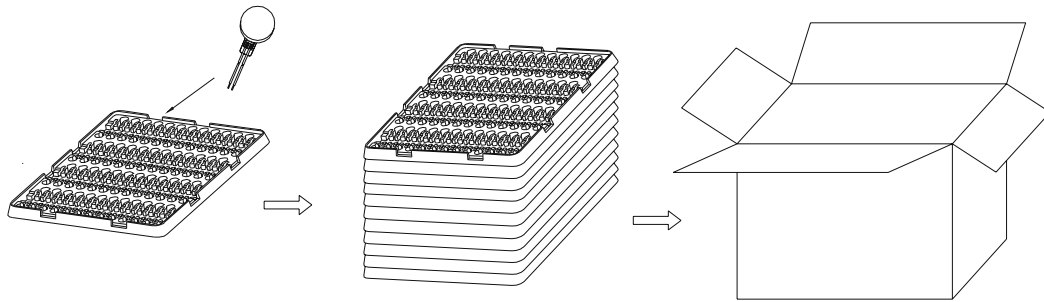
9. 包装/PACKING
**扁平系列马达包装
Pack drawing of coin type**

100PCS (1 tray) × 10

1000PCS (1 bundle)

1 box × 2

Remarks:

4000PCS/CTN: 45cm × 28cm × 20cm

6000PCS/CTN: 45cm × 28cm × 30cm

包装试验要求:

沿外包装箱 ±x, ±y 和 ±z 方向, 距水泥地面 1.5m 高度, 各自由跌落 2 次, 马达应无机械损伤, 电气性能仍符合标准要求。

Drop Test with carton:

Drop the carton in the axial directions of ±x, ±y, ±z onto the concrete floor from 1.5m height, drop twice each direction. After drop test, no mechanical damage to motors, and the electrical performances remain unchanged.

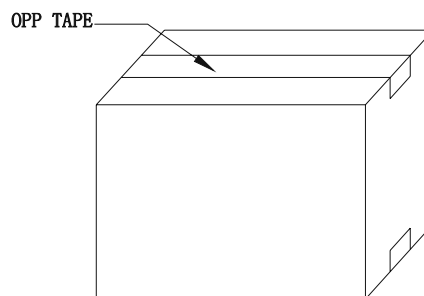

10. 外形图/ OUTLINE DRAWINGS

- 技术要求/Technic requirement
1. 额定电压/Rate voltage: 3.0V
 2. 额定电流/Rate current: 85mA Max
 3. 额定转速/Rate speed: 10,000rpm Min
 4. 启动电压/Starting voltage: 2.5V Max
 5. 端子阻抗/Terminal resistance:
30Ω ±20% (单相/Single phase)
60Ω ±20% (双相/Double phase)
 6. 在 DC 100V 直流下, 导线和机壳间绝缘电阻/
At DC 100V, that lead wire and case thin
out
the insulation resistance: > 10MΩ
 7. 导线规格/Lead spec: AWG32 UL3302
 8. 未注公差/Unmark tolerance: ± 0.1mm

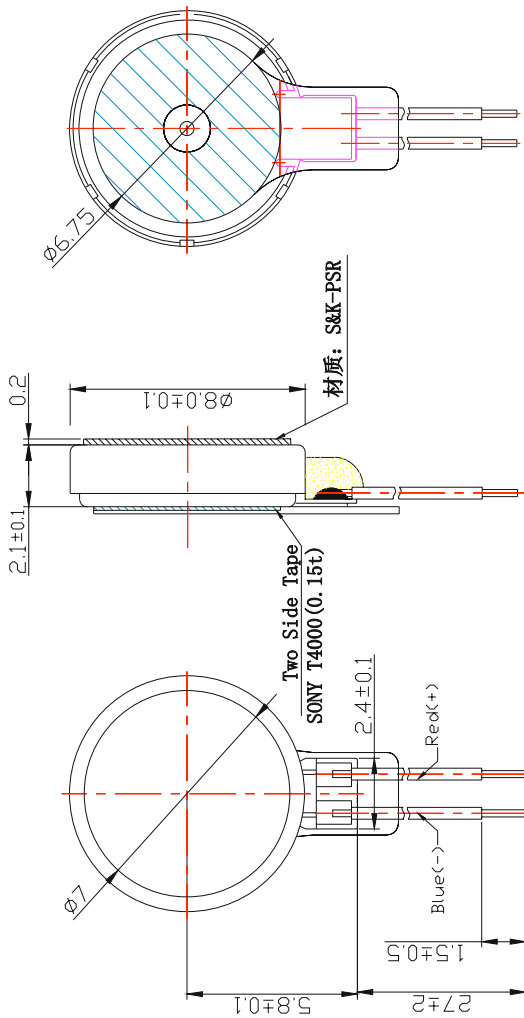

借(通)用件登记

底图总号

签字

日期

Vybronic		外形图		VC0820B006F	
标记	设计	校核	审核	工艺	日期
处	数	分	区	更改文件号	签名
				标准化	
				批准	
阶段标记		重量	比例	共 页 第 页	
A/0			5:1		

