



# 产品规格书

PRODUCT SPECIFICATION

客户名称Buyer Name	
客户料号Buyer Part No.	
客户承认签章 Buyers Approval & Signatures	

文件编号Spec No.		版本	A/2
品名描述 Product Description	扁平振动马达 Coin Type Vibration Motor		
型号Part No.	VC0720B088L		
送样日期Date			
设计Designed by	审核Checked by	批准Approved by	
陳满	陈满	陈满	
2021.09.30	2021.09.30	2021.09.30	

[www.vybronic.com](http://www.vybronic.com)

[sales@vybronic.com](mailto:sales@vybronic.com)

## - 目录/List -

封面/Cover-----	1
目录/Contents-----	2
更改记录/ Revision History-----	3
1. 适用范围/Scope Of Application-----	4
2. 使用条件/Standard Operating Condition-----	4
3. 测试条件/Testing Condition-----	5
4. 电气特性/Electrical Characteristic-----	5
5. 机械特性/Mechanical Characteristics-----	6
6. 环境试验/Environmental Test-----	7
7. 寿命试验/Life Test-----	9
8. 环保要求/Environment Protections-----	10
9. 注意事项/Caution-----	11
10. 附/Attached-----	12
10-1 马达特性图/Characteristic Graph Of Motor-----	12
10-2 标准测量方式/State Of Standard Measurement-----	12
11. 外形图/Outside View-----	13
12. 结构图及物料清单/Structure Drawing & BOM-----	14
13. 包装/Packaging-----	15



### 1.适用范围/Scope Of Application

本规格书适用于移动电话的振动电机。

This datasheet is stipulated for vibration motor, which is for mobile phone.

型号名称标准/Standard of model name:

VC 0720

→ 尺寸规格/Size Spec.:Φ07, 2.0t(例如/For Example 1227:Φ12,2.7t etc.)

→ VIBRATION MOTOR

### 2.使用条件/Standard Operating Condition

NO.	项目/Item	规格/Specifications
2-1	额定电压 Rated voltage	DC3.0V
2-2	使用电压范围 Operating voltage range	DC 2.5~3.5V
2-3	旋转方向 Rotating direction	CW / CCW
2-4	使用温度范围 Operating temperature range	-30°C~+70°C
2-5	保存环境范围 Storage temperature range	-40°C~+80°C

**3.测试条件/Testing Condition**

NO.	项目/Item	规格/Specifications
3-1	温度 Temperature	25°C±3
3-2	湿度 Humidity	45% ~85%RH
3-3	电源电压 Power supply, voltage source	直流电源或电池 3.0V DC power supply or battery 3.0V
3-4	马达安放状态 Posture of motor	标准测量方式 State of standard measurement

**4.电气特性/Electrical Characteristic**

NO.	项目/Item	单位 /Unit	规格/SPEC.	条件/Condition
4-1	额定转速 Rated speed	rpm	10000 Min	额定电压:DC 3.0V Rated voltage:DC 3.0V
4-2	额定电流 Rated current	mA	55Max	额定电压:DC 3.0V Rated voltage:DC 3.0V
4-3	启动电压 Starting voltage	V	2.3Max	DC2.3V电压下, 开/关为1个 循环, 共3个循环 On/off-1cycle,total 3cycles under DC2.3V
4-4	端子阻抗 Terminal resistance	Ω	相接触/ Phase contact: 50±20% 相串联/ Phase senrial: 90±20% 相并联/ Phase parallel: 25±20%	正极和负极之间 Between positive and negative
4-5	启动电流 Starting current	mA	80Max	启动电压:DC 2.3Max Starting voltage:DC 2.3Max
4-6	绝缘电阻 Insulationresistance	MΩ	10Min	测量机壳和引线之间。 测试电压直流100V。 Measuring between case and lead wire.Test voltage DC 100V

**5.机械特性/Mechanical Characteristics**

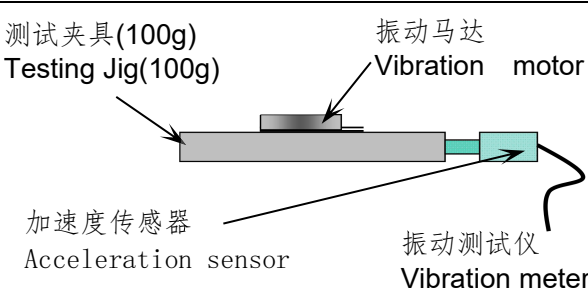
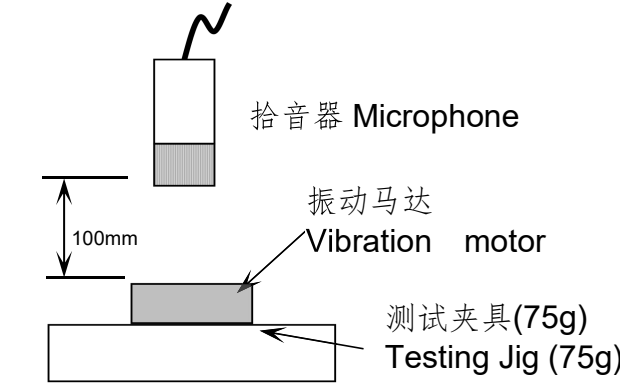
NO	项目/Item	单位/Unit	规格/Spec	条件/Condition
5-1	振动量 Vibration Strength	Grms	0.1 Min	测试夹具(100g) Testing Jig(100g)  振动马达 Vibration motor 加速度传感器 Acceleration sensor 振动测试仪 Vibration meter
		Gp	0.15Min	马达: 被固定/Motor : be fixed. 额定电压:DC 3.0V/Rated voltage : DC 3.0V .
5-2	机械噪音 Mechanical Noise	dB	50 Max	 拾音器 Microphone 100mm 振动马达 Vibration motor 测试夹具(75g) Testing Jig (75g)
5-3	底盖偏转强度 Bracket Deflection Strength	gf	1000 Min	通过推拉计进行破坏测试 Demolition test by push-pull gauge.

**6.环境试验/Environmental Test**

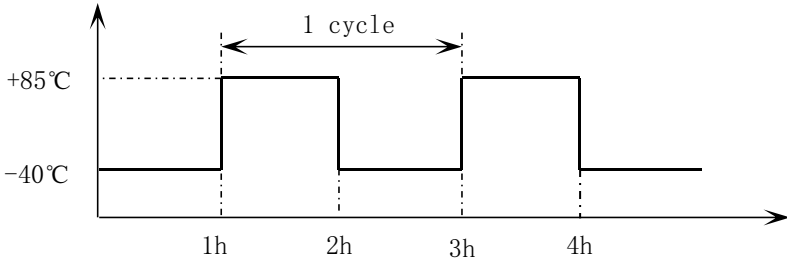
NO	项目/Item	条件/Condition
6-1	低温贮存试验 Low temperature Storage test	在-40℃的环境下放置96小时，然后在常温常湿下恢复2小时后测试。 Exposed at -40℃ for 96hours, then return to normal temperature and humidity for 2 hours before test.
6-2	高温贮存试验 High temperature Storage test	在+80℃的环境下放置96小时，然后在常温常湿下恢复2小时后测试。 Exposed at +80℃ for 96hours, then return to normal temperature and humidity for 2 hours before test.
6-3	高湿贮存试验 High humidity Storage test	在+40℃,90%RH的环境下放置96小时，然后在常温常湿下恢复2h后测试。 Exposed at +40℃ 90%RH for 96hours, then return to normal temperature and humidity for 2 hours before test.
6-4	温冲试验 Thermal shock test	<p>马达按照以下试验条件放置 15 个周期，然后在常温常湿下放置 2 小时后测试。 Confirmed to operating of motor during 15 cycles as following test condition, then return to normal temperature and humidity for 2 hours before test.</p> <p>试验条件/Test condition:</p>  <p>高低温转换时间：≤5分钟 Transfer time between high temperature and low temperature:≤5min</p>
6-5	跌落 Drop test	将马达固定在100g的塑料夹具上，从1.5米的高度跌落到水泥地面上，六个面的每个面都跌落2次。 The motor that is attached to a 100g jig (plastic housing) and drop it onto the concrete floor from 1.5m height. Drop twice in each of the six planes.

6-6	振动试验 Vibration test	将马达固定在100g的塑料夹具上，按以下要求进行试验： 1)振频范围:10-55Hz 2)全振幅1.5mm 3)振频变化10-55-10 约10分钟 4)振动方向:三个垂直方向 5)持续时间:每个方向10分钟（共30分钟） The motor that is attached to a 100g jig (plastic housing) and test according following condition: 1)Vibration frequency range: 10~55Hz 2)Total amplitude: 1.5mm 3)Sweep ratio: 10~55~10Hz approximate 10min 4)Direction of vibration: Three perpendicular directions 5)Duration: 10min(30min in total)
-----	------------------------	--

▶ 判定标准/Judgment standard

① 试验后，测试数据必须符合以下规格：

After test, measured data must be satisfied as following specifications;

- 启动电压: DC2.3V Max.
- Starting voltage: DC2.3V Max.
- 额定转速: 变化率在初始值的-30%~+50%以内。
- Rated speed: changing rate must be within -30%~+50% of initial value.
- 额定电流: 变化率在初始值的-30%~+50%以内。
- Rated current: changing rate must be within -30%~+50% of initial value.
- 端子阻抗: 变化率在初始值的±15%以内。
- Terminal resistance: changing rate must be within ±15% of initial value.

② 外形结构无异常。

There should be no abnormalities in appearance and structure.



### 7.寿命试验/Life Test

▶ 试验条件/Test condition:

1 秒转, 1 秒停为 1 个周期, 共 10 万次。

( DC3.0V, 常温常湿)

1 SEC ON, 1SEC OFF 1CYCLE , 100,000 CYCLES.

( DC3.0V, at normal temperature and humidity )

▶ 判定条件/Judgment standard:

试验后, 测试数据必须符合以下规格:

After test, measured data must be satisfied as following specifications;

- 启动电压: DC2.3V Max.
- Starting voltage: DC2.3V Max.
- 额定转速: 变化率在初始值的-30%~+50%以内。
- Rated speed: changing rate must be within -30%~+50% of initial value.
- 额定电流: 变化率在初始值的-30%~+50%以内。
- Rated current: changing rate must be within -30%~+50%of initial value.

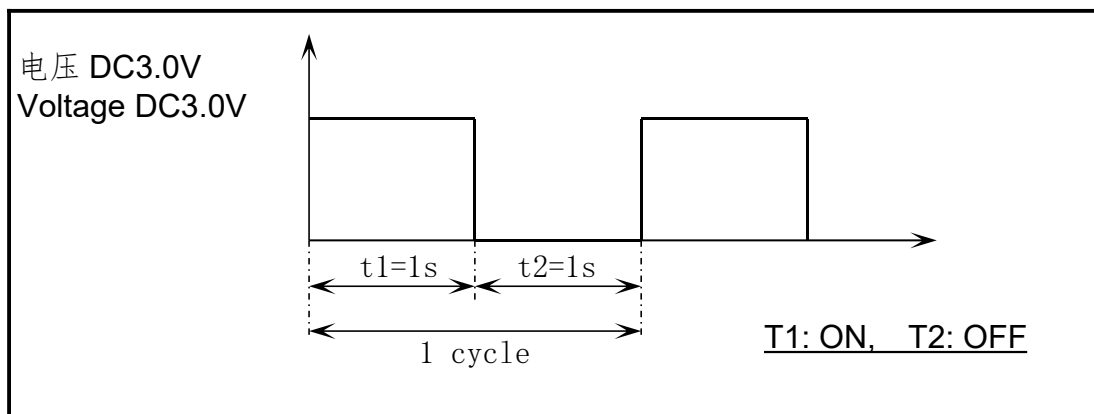

**8.环保要求/Environment Protections**

本产品所有零部件符合欧盟RoHS指令（2011/65/EU,(EU)2015/863）/无卤/REACH指令要求，具体环境有害物质管控限制如下/This product conforms to the EU ROHS（2011/65/EU,(EU)2015/863）， Halogen-Free and REACH certification, Specific content as follows:

铅及其化合物最大允许含量为1000ppm/Lead and Lead compounds≤1000ppm

镉及其化合物最大允许含量为100ppm/Cadmium and cadmium compounds≤100ppm

汞及其化合物最大允许含量为1000ppm/Mercury and Mercury compounds≤1000ppm

六价铬化物最大允许含量为1000ppm/Hexavalent chromium compounds≤1000ppm

多溴联苯(PBB)最大允许含量为1000ppm/Polybrominated biphenylethers≤1000ppm

多溴联苯醚(PBDE)最大允许含量为1000ppm/Polybrominated diphenylethers≤1000ppm

邻苯二甲酸二异丁酯（DIBP）最大允许含量为1000ppm /DIBP≤1000ppm

邻苯二甲酸二丁酯(DBP)最大允许含量为1000ppm /DBP≤1000ppm

邻苯二甲酸苄基酯(BBP)最大允许含量为1000ppm/BBP≤1000ppm

邻苯二甲酸二（2-乙基己基）酯(DEHP)最大允许含量为1000ppm/DEHP≤1000ppm

六溴环十二烷(HBCDD)最大允许含量为1000ppm/HBCDD≤1000ppm

溴Br最大允许含量为900ppm/Br≤900ppm

氯Cl最大允许含量为900ppm/Cl≤900ppm

溴加氯之和最大允许含量为1500ppm/Br+Cl≤1500ppm

REACH 指令按最新法规内容管控执行/The instructions are subject to the latest regulations

包装材料环保管控要求/Environmental control requirements for packaging materials

: Pb+Cd+Hg+Cr6 < 100ppm (其中, Cd<50ppm)

**9.注意事项/Caution**

- (1) 该马达是微型精密产品，在运输过程中不要承受超过0.5 kgf的力，否则会引起外形或性能的变化。

As this motor is small and precise, do not press it over 0.5kgf force or while transportation, it can cause the transformation of performance or external appearance.

- (2) 请注意马达不要接触到液体性物质（比如：水，酒精等）

please be careful, not to be contacted fluid substances (such as: water, alcohol etc.)

- (3) 不要在高温下长时间放置，否则有可能导致电机的性能下降。

Do not expose the motor to high temperature for a long periods of time, it may cause a decline in performance.

- (4) 马达不要在以下环境中使用：

- 高温和高湿的场所
- 腐蚀性气体如H<sub>2</sub>S、SO<sub>2</sub>、NO<sub>2</sub>等
- Avoid using the motor in the following environment.
- High temperature and high humidity area.
- Corrosive gas such as H<sub>2</sub>S、SO<sub>2</sub>、NO<sub>2</sub> etc.

- (5) 请不要在靠近磁铁或带有磁场的仪器旁边使用或存放马达。

Please do not operate or store the motor adjacent to magnet or apparatus That has a magnetic field.

- (6) 请注意底盖的表面存在漏磁通量。

Please be careful that there exists a leaking magnetic flux on the surface of bracket.

- (7) 电刷和换向器的相互作用，有可能产生轻微的电噪音。

Due to interaction between brush and commutator, there is a possibility to occur electrical noise slightly.

- (8) 因测试设备有误差，允许有±5%偏差。

Beacuse there is error of the measurement equipment ,permit the standard of the rotational frequency to ±5%

**10.附/Attached**

**10-1 马达特性图/Characteristic Graph Of Motor**

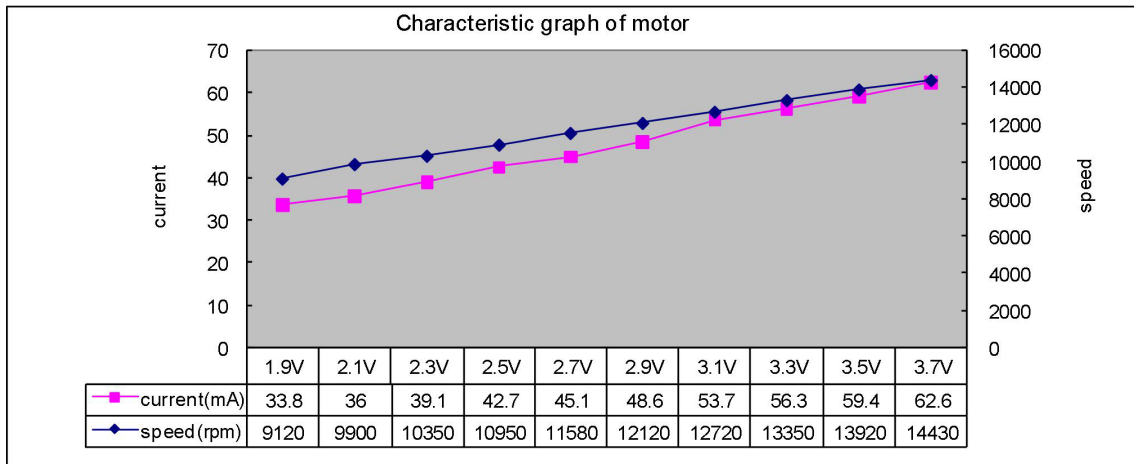

**10-2 标准测量方式/State Of Standard Measurement**

测试项目：启动电压，额定电压下的电流，额定电压下的转速，绝缘电阻。

Measure item: starting voltage, current at rated voltage, speed at rated voltage, insulation resistance.

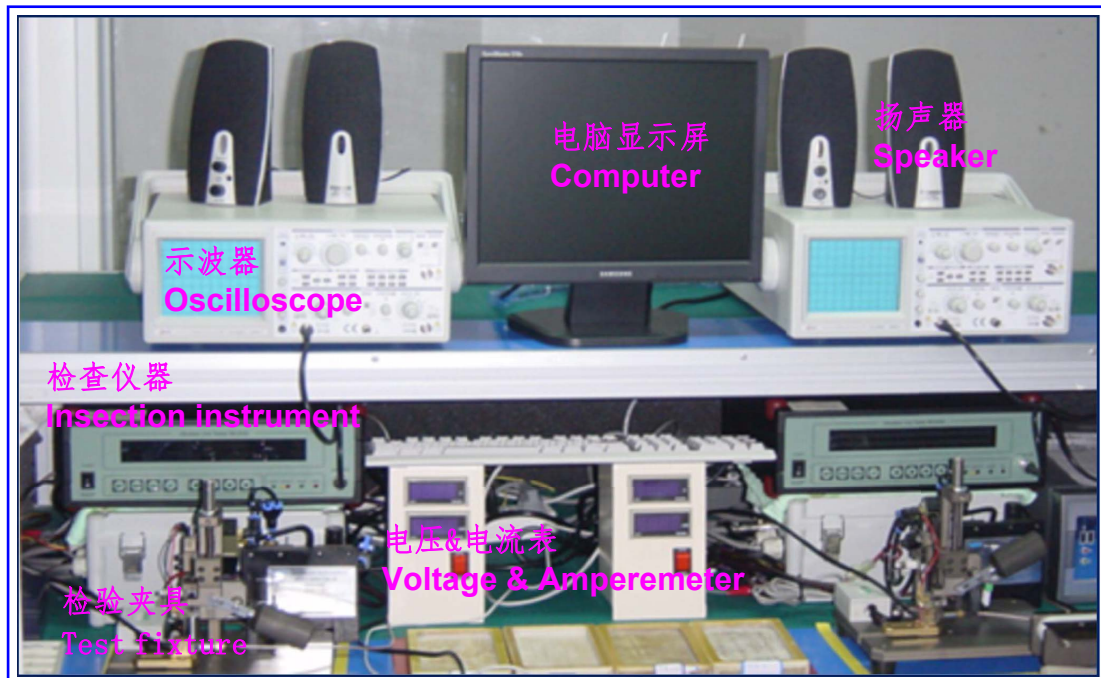

11. 外形图/Outside View

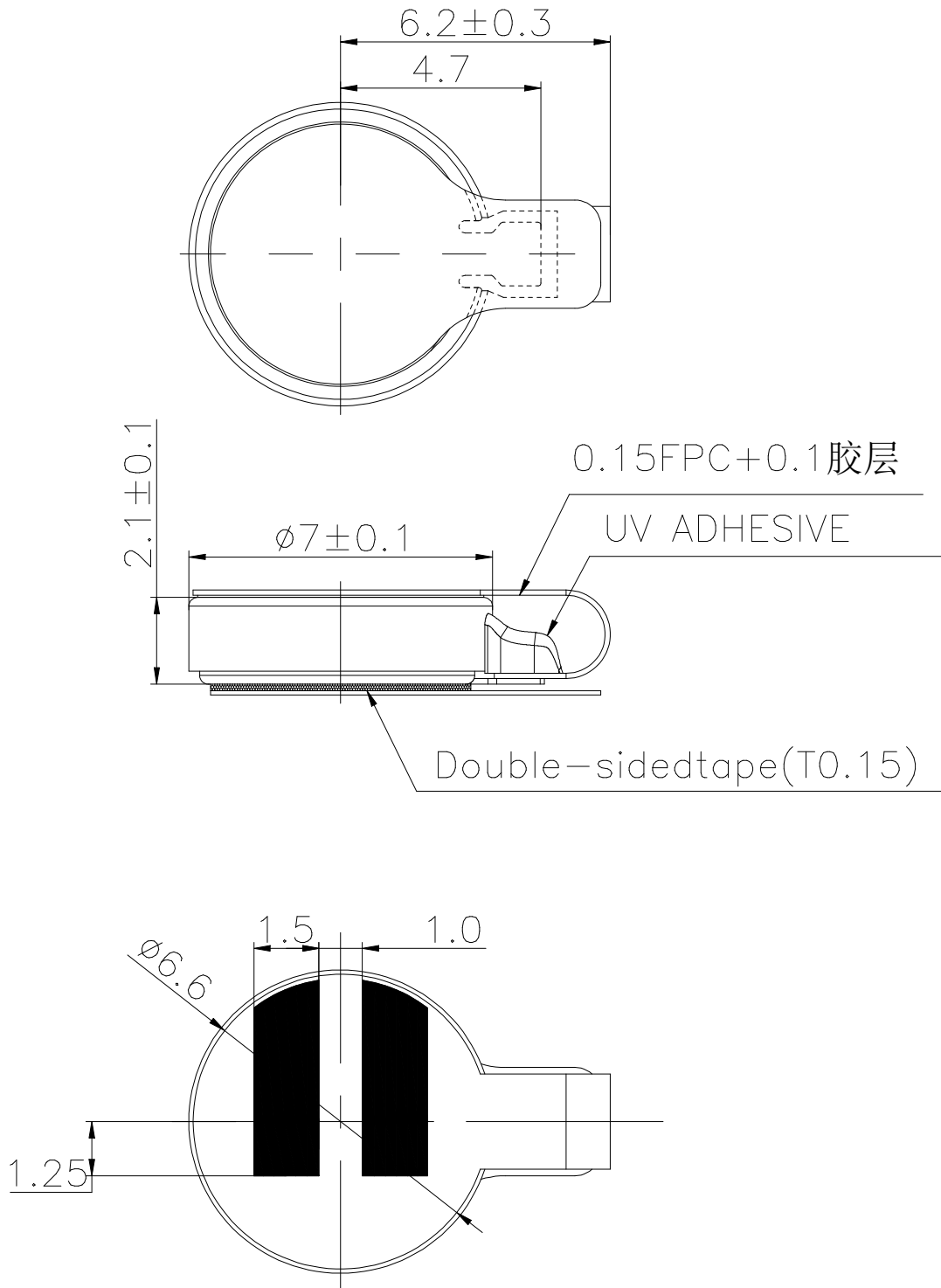

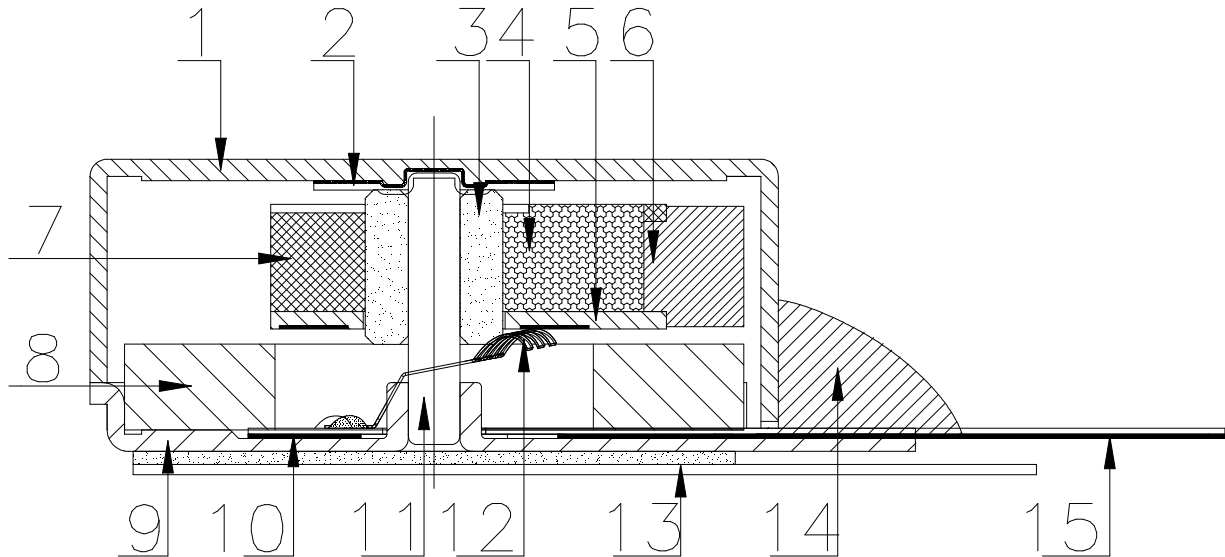
**12. 结构图及物料清单/Structure Drawing & BOM**

NO.	物料名称/Part name	材料/Material
1	上机壳 Upper case	SPC-E
2	滑片 Slide	PE+Acrylic
3	轴承 Bearing	Cu+Fe
4	线圈 Coil	Copper+PU
5	硬基板 HPCB	Epoxy
6	振子 Weight	Tungsten alloy
7	塑料 Resin	PBT
8	磁钢 Magnet	NdFeB
9	下机壳 Lower case	SPC-E
10	软基板 FPCB	PI+AD+Copper+Glue
11	钢轴 Shaft	DSR7B
12	电刷 Brush	MX215
13	双面胶 Double-sided tape	Cloth+Adhesive
14	UV 胶水 UV adhesive	Acryloid cement
15	软基板 FPCB	PI+AD+Copper+Glue

**13.包装/Packaging**

吸塑盒尺寸(长:250mm 宽:210mm 高:11mm)  
Tray dimension (L:250mm W:210mm  
H:11mm)  
每个吸塑盒放 100 只  
100 Pcs per tray

内箱尺寸(260mm 宽:215mm 高:80mm)  
Inner-box dimension (L:260mm W:215mm  
H:80mm)  
每 11 个吸塑盒捆在一起,数量为 1000 只,装  
入内箱  
Put into inner-box 11 tray together  
with tape 1000 Pcs per 11 tray .

4 个内箱装入外箱, 数量共 4000 只;  
Put 4 inner-box into outer-box, total 4000  
Pcs.  
外箱尺寸: (450mm 宽:280mm 高:180mm)  
Outer-box dimension:  
(L:450mm W:280mm H:180mm)